

National Certificate in Building, Construction and Allied Trades Skills (BCATS)

**Read and interpret plans, working
drawings and specifications for
BCATS projects**

Unit Standard – 22607

Level 2, Credit 3

Name: _____





Contents

<i>Reference</i>	<i>Page</i>
What you need to do	1
Glossary of terms	2
Sketches and working drawings	3
Lines	5
Symbols	6
Orthographic working drawings	7
Pictorial working drawings	11
Plans and specifications	12

Published by: Building and Construction Industry Training Organisation (BCITO)

Level 5, 234 Wakefield Street
PO Box 2615
Wellington

© BCITO

All rights reserved.

No part of this work may be reproduced, adapted, modified, copied or transmitted in any form or by any means, including by way of example only, written, graphic, electronic, mechanical, reprographic, photocopying, recording, taping or information retrieval systems, without the written permission of the publisher.

What you need to do

By the end of this module, you should be able to:

- read and interpret plans, working drawings and specifications.

During this module, you need to show your teacher/tutor that you can:

- identify plans, working drawings and specifications and describe what they are used for;
- identify and interpret abbreviations and symbols on plans, working drawings and specifications;
- identify any preliminary work from plans, working drawings and specifications; and
- use plans, working drawings and specifications to determine the quality and types of materials required.

How you will be assessed

For assessment, your teacher/tutor will give you a worksheet that you need to complete, which your teacher/tutor will mark.

Glossary of Terms

Term	Meaning
Abbreviations	Shortened versions of words used to identify construction-related information and features
Freehand sketches	An important, convenient and simple method of communicating information and ideas
Isometric view	A pictorial drawing which shows three faces of an object at 30°
Oblique drawing	A pictorial drawing which shows two faces of an object inclined at 45°
Orthographic	An arrangement of views which fully describes the six sides of an object
Perspective drawings	Perspective drawings provide a realistic view of an object
Pictorial drawings	A method of drawing which represents an object as a picture
Plans	A term used to describe a set of working drawings
Scale drawings	Drawings of objects that are proportionally enlarged or reduced to suit the size of the drawing paper
Specifications	Written instructions for a project which are read in conjunction with and relate to the working drawings
Symbols	Small architectural symbols used to represent common construction items
Working drawings	A set of drawings which provide the necessary information to complete a project

Sketches and Working Drawings

The objective of working drawings is to present clear, concise and easily read information on a proposed building project, so everyone connected with the project is fully aware of what exactly is required. Various types of drawing methods are used to communicate this information.

Architectural drawing is an international language used to communicate ideas and information in a graphic form. Using standard conventions reduces the amount of space needed to communicate important features and information.

Usually freehand sketches are prepared first. Final working drawings and specifications are completed once the design details have been decided on. Each drawing should be neat, to scale and clearly labelled.

To achieve this unit standard you need to have a good understanding of the various lines and symbols used in working drawings, and be able to prepare working drawings for the construction projects you undertake.

Drawing to scale

When preparing a set of working drawings it is usually impossible to draw objects full size, so the building project or its location must be reduced proportionally to allow it to fit on conveniently sized drawing paper.

This reduction process is called scaling and should be clearly recorded on the drawing.

A scale of 1:100 means 1mm will represent 100mm on the drawing.

Common scales used for construction drawings:

- Site plans 1:200, 1:500
- Floor/foundation plans 1:100, 1:50
- Elevations 1:100, 1:50
- Cross sections 1:100, 1:50

Where an object needs to be shown larger than full size, scales of 2:1, 5:1 or 10:1 can be used.

It is important to select the correct scale on the scale rule to correspond to the one noted on the drawing.

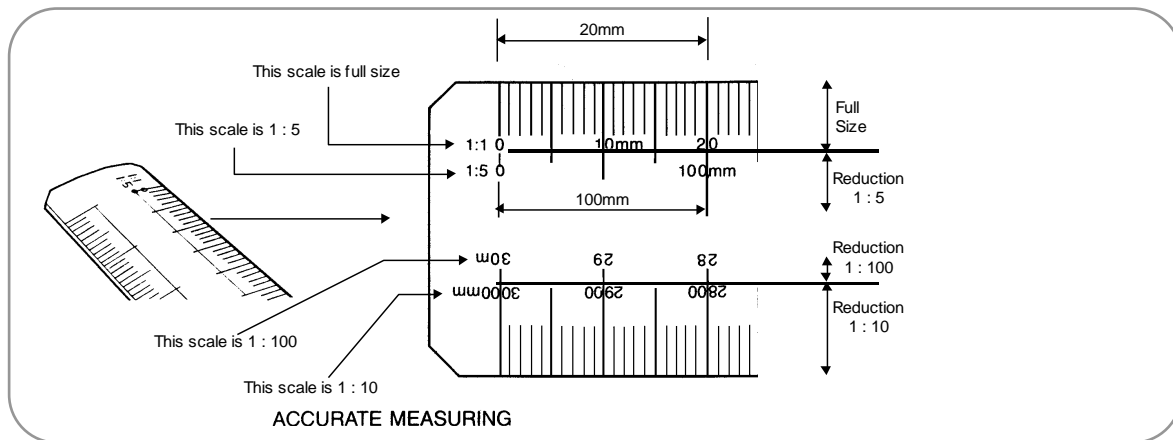

- If full-size measurements are required, use the readings above the line.
- For a reduction scale, use the figures below the line.

It is also a good idea to check that the measurements written on the drawings are correct. (For example, a drawing may have been enlarged or reduced using a photocopier and the scale may not be accurate.)

Lines

There is a range of different types of lines used in preparing construction drawings, each of which has a different purpose.

These lines are drawn using one of three thicknesses:

- thick;
- thin; or
- very thin.

Type of line	Description	Uses
	Continuous (thick)	Visible outline and edges
	Continuous (thin)	Fictitious outlines and edges Dimension and leader lines Hatching Outlines of adjacent parts Outlines of revolved sections Fold lines
	Continuous irregular (thin)	Limits of partial views or sections when the line is not an axis
	Short dashes (thin)	Hidden outlines and edges
	Chain (thin)	Centre lines, extreme position of movable parts
	Chain (thick at ends and at changes of direction, thin elsewhere)	Section and planes
	Thin	Break (architectural)
	Chain (thin)	Geometric datum (reference line)
	Continuous very light but clearly visible	Construction lines

Symbols and abbreviations

Symbols are used on construction drawings and are usually drawn without an abbreviation.

Below are examples of various common symbols and their application to a simple construction project.

Symbol	Meaning	Symbol	Meaning
	Fluorescent light		Door
	Window		Light switch
	Roller shutter door (rsd)		Distribution board
	Electrical socket outlet		Hardcore fill
	Concrete		Timber
	Soil (earth)		

Some abbreviations can be found on the floor plan below, such as U/G for underground, RSD for roller shutter door and WM for washing machine

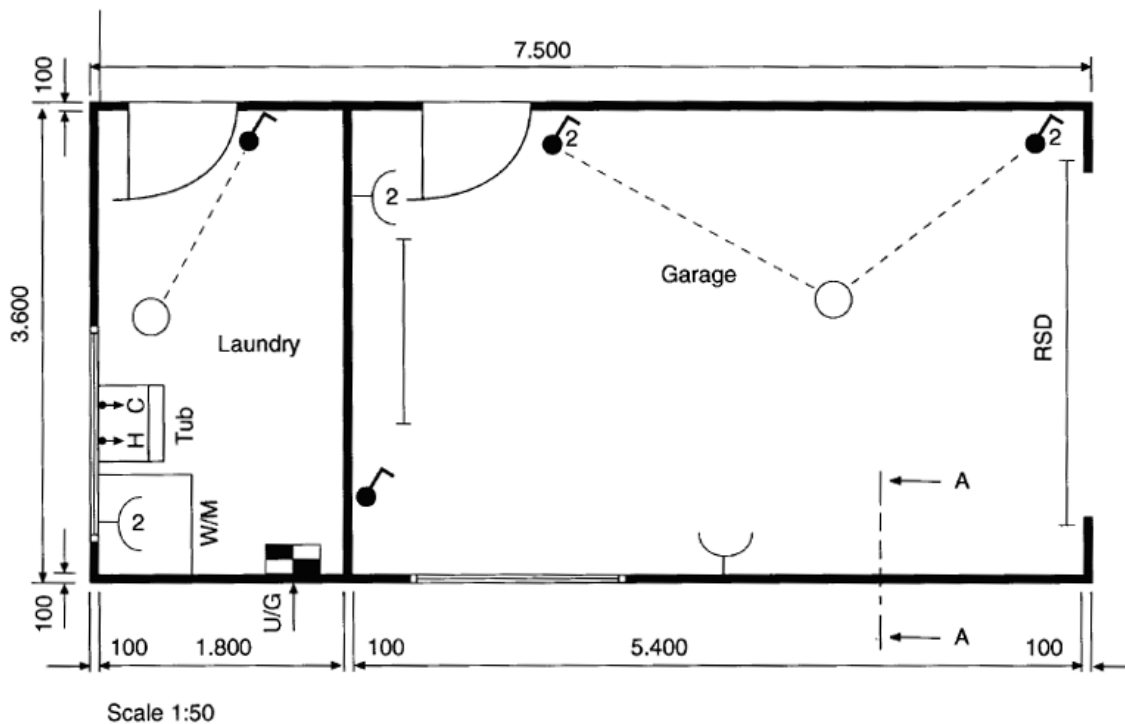

Orthographic Working Drawings

Orthographic working drawings are flat views of one face of the construction project, and include plans, elevations and sectional views.

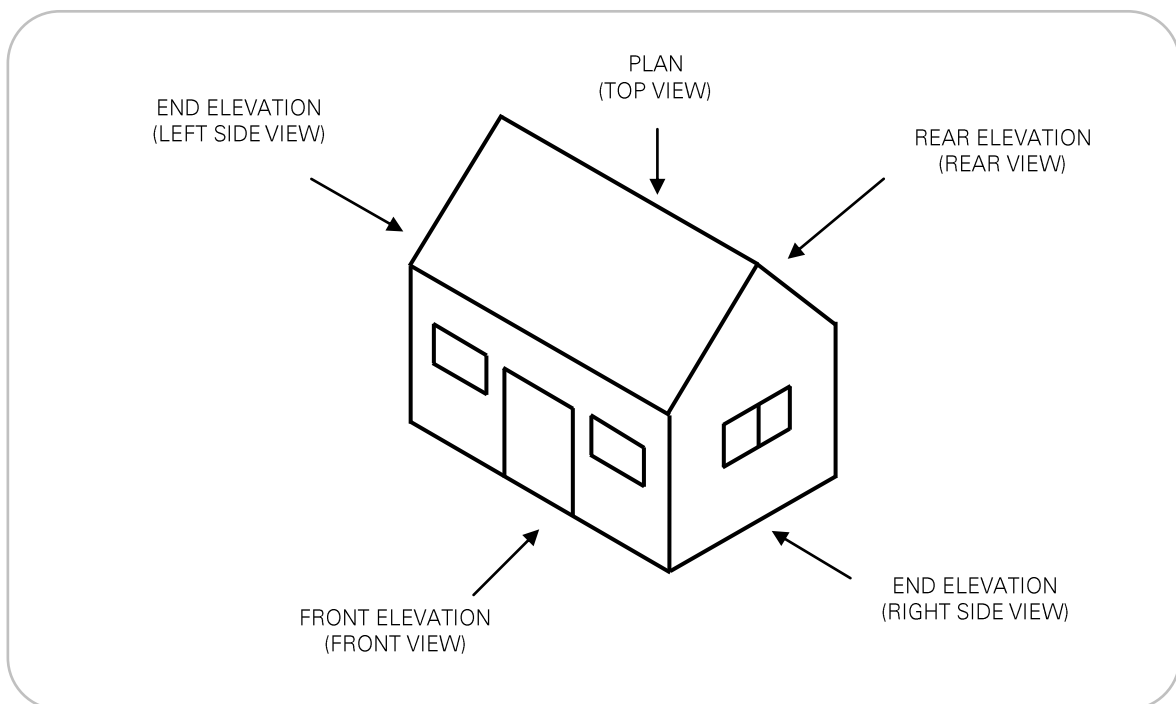
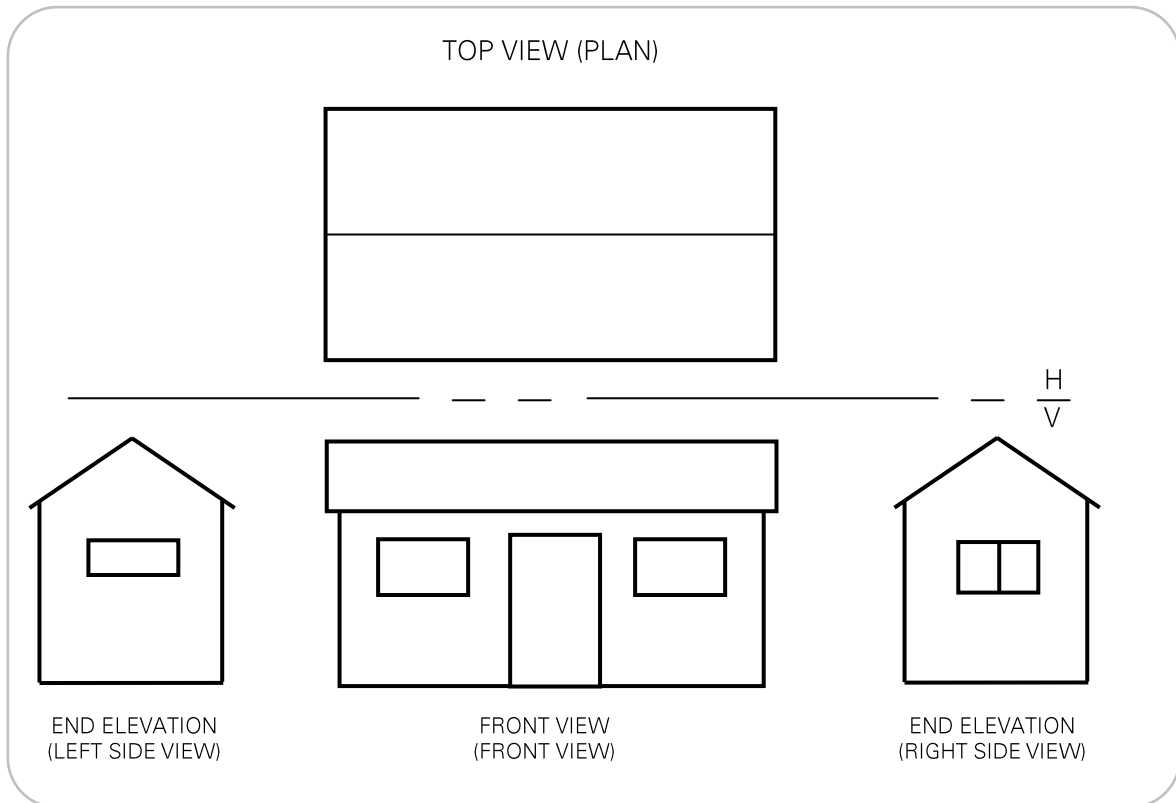

Plans

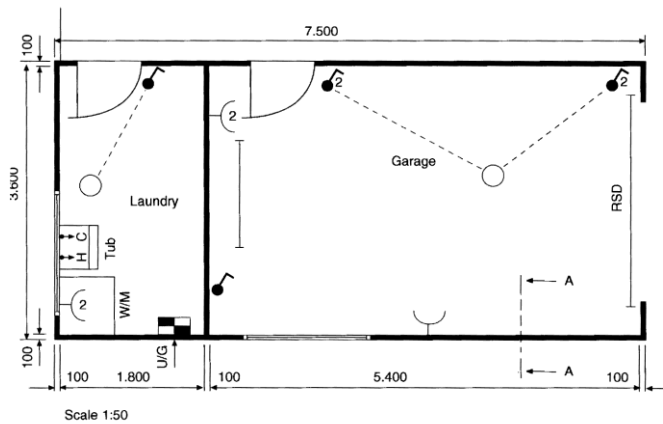

The plan is the view seen when looking directly down from above. It can provide information about:

- overall length and width;
- dimensions of parts of the construction;
- position and size of window and door openings;
- function of areas;
- position of elements such as bath, shower, etc;
- section planes, for sectional elevations;
- scale of the plan (usually 1:50);
- location of the drawing; and
- outline of the roof shape.



Note: Refer to above diagram.

Elevations

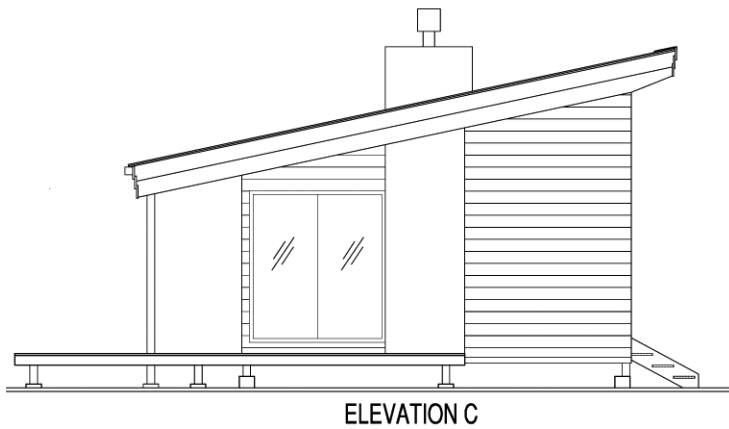

Each elevation is the view from one side of the construction when looking at it from outside. It can provide information about:

- shape of the construction from each direction;
- height of the construction;
- positions of doors and windows;
- window details and height;
- roof shape and cladding;
- type of exterior cladding and other finishing materials; and
- position of porches, decks, garages or carports.



Note: Refer to above diagram.

Cross-sectional views

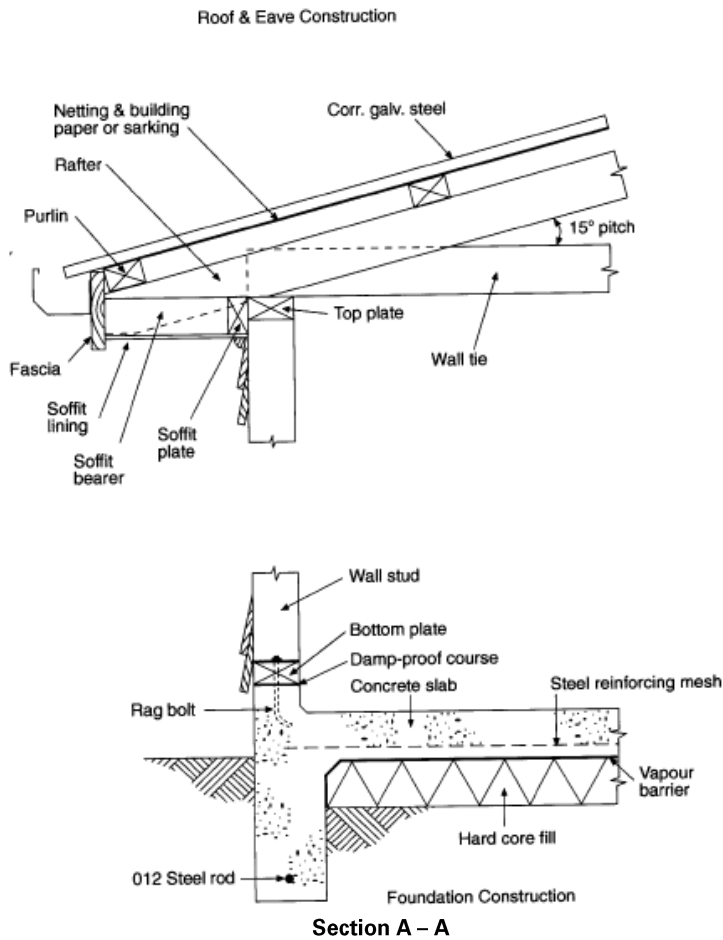

It is often necessary to show the details (that are normally hidden) of an object or structure. To do this it is necessary to imagine that it has been cut through or sectioned. The line along which an object is sectioned is called a cutting plane. The position of a cutting plane should be indicated on another view using a section line.

A cross-sectional, or section, view differs from an elevation, as it shows the details through the construction. It can provide information about:

- foundation shape and sizes and positioning of reinforcing steel;
- sub-floor construction, including piles, framing materials, bracing;
- floor and ground levels;
- roof construction and pitch;
- floor and ground levels; and
- window and door heights.



Note: Refer to above diagrams.

Pictorial Working Drawings

Pictorial working drawings are used to provide a more realistic impression of what an object or building will look like.

Pictorial drawings can include:

- isometric views
- oblique views.
- one point perspective
- two point perspective

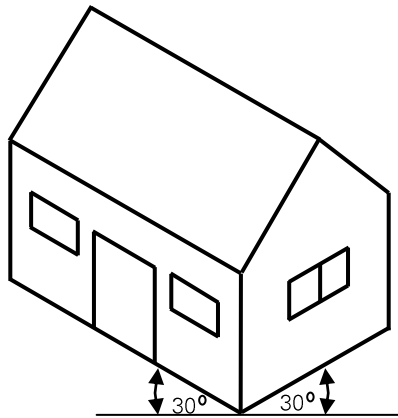

ISOMETRIC

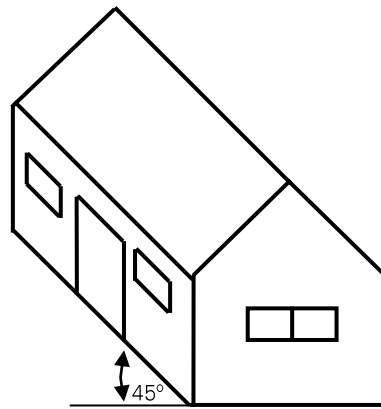

OBLIQUE

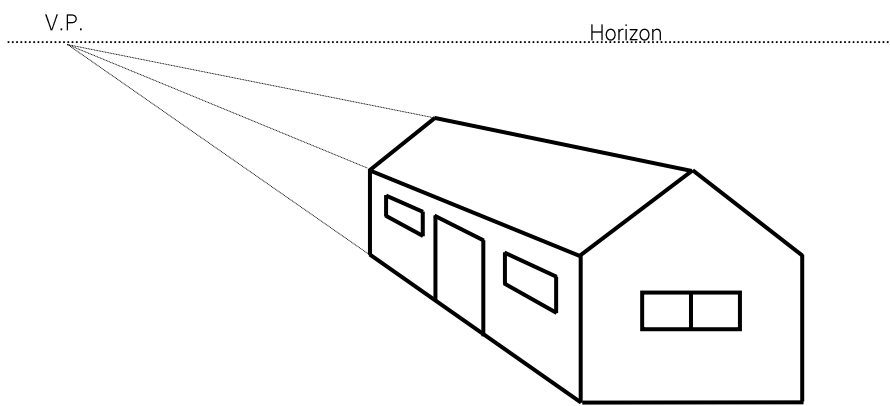

ONE POINT PERSPECTIVE

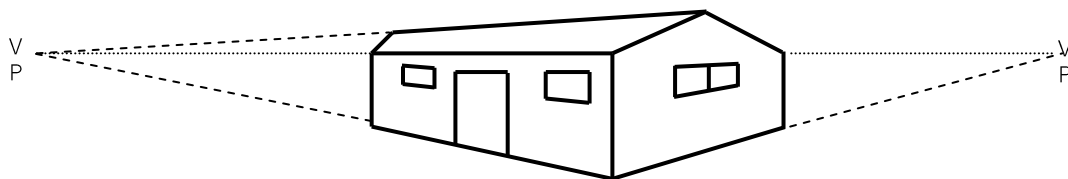

TWO POINT PERSPECTIVE

Plans and Specifications

Plans and specifications are the means of communication between all parties involved in a building project.

Plans and specifications for building work are required to:

- show compliance with the functional and performance requirements of the Building Code so that a building consent can be obtained under the terms of the Building Act;
- allow the work to be accurately priced/estimated; and
- allow the work to be correctly constructed as envisaged by the designer and form part of the contractual agreement between the owner and the builder.

Working drawings

Two copies of each must be provided. The content of the working drawings must include:

- **Site plan(s)** – These will indicate the boundaries, drainage, existing buildings, site datum, finished floor levels and other relevant information.
- **Foundation plans** – (showing bracing elements):
 - floor plans;
 - exterior wall elevations - showing finished ground level;
 - a typical cross section - showing construction details, finished floor level, stud heights and construction sizes;
 - roofing plan - showing framing sizes and bracing;
 - wall bracing positions - complete with all calculations; and
 - details of any special construction requirements or elements.

Specifications

The specifications are an extension of working drawings – both documents complement each other. While certain important written information is necessary on a drawing, for clarity, this should be kept to a minimum, simply indicating the shape, location and size of objects which are identified by a name or title.

The specifications are the written instructions which contain all the relevant information relating to:

- standard of work;
- quality of materials;
- contractual responsibilities;
- extent of work for each trade; and
- finishing schedules.