

**National Certificate in Building, Construction and Allied Trades Skills (BCATS)**

**Demonstrate knowledge of and  
create sketches and drawings for  
BCATS projects**

Unit Standard – 24353

Level 2, Credit 6

**Name:** \_\_\_\_\_





# Contents

<i>Reference</i>	<i>Page</i>
What you need to do	1
Glossary of terms	2
Sketches and working drawings	3
Lines	5
Symbols	6
Orthographic working drawings	7
Pictorial working drawings	11
Drawing equipment	14
Freehand drawing	17

**Published by: Building and Construction Industry Training Organisation (BCITO)**

Level 6, 234 Wakefield Street  
PO Box 2615  
Wellington

© BCITO

All rights reserved.

No part of this work may be reproduced, adapted, modified, copied or transmitted in any form or by any means, including by way of example only, written, graphic, electronic, mechanical, reprographic, photocopying, recording, taping or information retrieval systems, without the written permission of the publisher.

## What you need to do

By the end of this module, you should be able to:

- demonstrate knowledge of lines and symbols, and drawing and sketching methods, used to produce construction drawings;
- establish job requirements and create sketches; and
- convert sketches to instrumental drawings.

### **How you will be assessed**

You will be assessed by a combination of practical and written work.

To achieve this unit standard, you need to prepare sketches and working drawings for 2 basic construction projects or design briefs; for example, wooden garden furniture, a deck, a non-consent building, a dog kennel, a pergola, a fence and gate, a kitset garden shed. Your teacher/tutor will tell you which projects to complete.

You need to show your teacher/tutor that you can:

- explain the lines and symbols used on construction drawings;
- recognise drawing and sketching methods and what they are used for;
- read or listen to the job instructions, check anything you're not sure of, and choose which sketching technique to use;
- gather sketching equipment and create sketches;
- gather drawing equipment and use sketches to create drawings that are complete and correct (you need to complete an elevation, a plan, a cross section, and **2** of an isometric drawing, an oblique drawing, a one-point perspective drawing, or a 2-point perspective drawing);
- ensure that the drawings contain correct lines, show required scale, and detail; and
- store sketches, drawings, equipment and unused materials.

Your teacher/tutor will also give you a worksheet that you need to complete, which your teacher/tutor will mark.

## Glossary of Terms

Term	Meaning
Abbreviations	Shortened versions of words used to identify construction related information and features
Freehand sketches	An important, convenient and simple method of communicating information and ideas
Isometric view	A pictorial drawing which shows three faces of an object inclined at 30°
Oblique drawing	A pictorial drawing which shows three faces of an object one face parallel to the plane of projection and the other 2 faces inclined at 45°
Orthographic	An arrangement of views which fully describes the six sides of an object
Perspective drawings	Perspective drawings show an object as it is seen by the human eye and provide a realistic view
Pictorial drawings	A drawing method which represents an object as a picture including isometric, oblique and perspective projections
Plans	A term used to describe a set of working drawings
Scale drawings	Drawings of objects that are proportionally enlarged or reduced to suit the size of the drawing paper
Specifications	Written instructions for a project which are read in conjunction with and relate to the working drawings
Symbols	Small architectural symbols used to represent common construction items
Working drawings	A set of drawings which provide the necessary information to complete a project

# Sketches and Working Drawings

Architectural drawing is an international graphic language used to communicate precise ideas and information from one person to another. Using standard conventions reduces the amount of space needed to communicate important features and information.

A student may have no intention of following a career in drawing, however drawing is not just for the architect, engineer, artist or fashion designer. Drawings are found wherever there is a need to learn, record, teach, explain and make complex information more understandable.

In everyday life the use of drawings is increasing and to read them a person needs to develop special knowledge and skills.

The objective of working drawings is to present clear, concise and easily read information on a proposed building project, so everyone connected with the project is fully aware of what exactly is required. Various types of drawing methods are used to communicate this information.

Usually, freehand sketches are prepared first, and then final working drawings and specifications are completed once the design details have been decided on. Each drawing should be neat, to scale and clearly labelled.

To achieve this unit standard you need to have a good understanding of the various lines and symbols used in working drawings, and be able to prepare working drawings for the construction projects you undertake.

## **Drawing to scale**

When preparing a set of working drawings it is usually impossible to draw objects full size, so the building project or its location must be reduced proportionally to allow it to fit on conveniently sized drawing paper.

This reduction process is called scaling and should be clearly recorded on the drawing.

A scale of 1:100 means 1mm will represent 100mm on the drawing.

Common scales used for construction drawings:

- Site plans 1:200, 1:500
- Floor/foundation plans 1:100, 1:50
- Elevations 1:100, 1:50
- Cross sections 1:100, 1:50

Where an object needs to be shown larger than full size, scales of 2:1, 5:1 or 10:1 can be used.

It's important to select the correct scale on the scale rule to correspond to the one noted on the drawing.

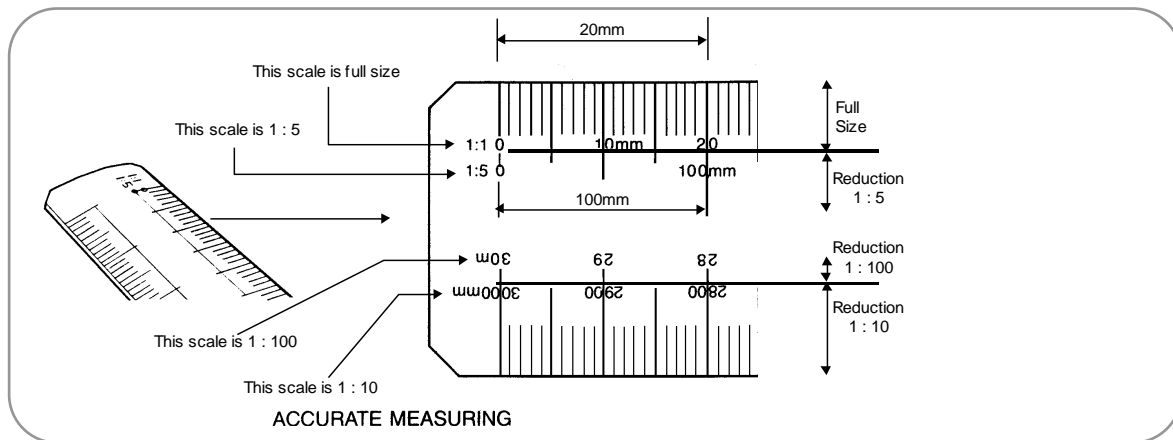

- If full-size measurements are required, use the readings above the line.
- For a reduction scale, use the figures below the line.

It's also a good idea to check that the measurements written on the drawings are correct. (For example, a drawing may have been enlarged or reduced using a photocopier and the scale may not be accurate.)

**Lines**

There is a range of different types of lines used in preparing construction drawings, each of which has a different purpose.

These lines are drawn using one of three thicknesses:

- thick;
- thin; or
- very thin.

Type of line	Description	Uses
	Continuous (thick)	Visible outline and edges.
	Continuous (thin)	Fictitious outlines and edges. Dimension and leader lines. Hatching. Outlines of adjacent parts. Outlines of revolved sections. Fold lines.
	Continuous irregular (thin)	Limits of partial views or sections when the line is not an axis.
	Short dashes (thin)	Hidden outlines and edges.
	Chain (thin)	Centre lines, extreme position of movable parts.
	Chain (thick at ends and at changes of direction, thin elsewhere)	Section and planes.
	Thin	Break (architectural).
	Chain (thin)	Geometric datum (reference line).
	Continuous, very light but clearly visible	Construction lines.

# Symbols

Symbols are used on construction drawings and are usually drawn without an abbreviation.

Below are examples of various common symbols and their application to a simple construction project.

Symbol	Meaning	Symbol	Meaning
	Fluorescent light		Door
	Window		Light switch
	Roller shutter door (RSD)		Distribution board
	Electrical Socket outlet		Hardcore fill
	Concrete		Timber
	Soil (earth)		

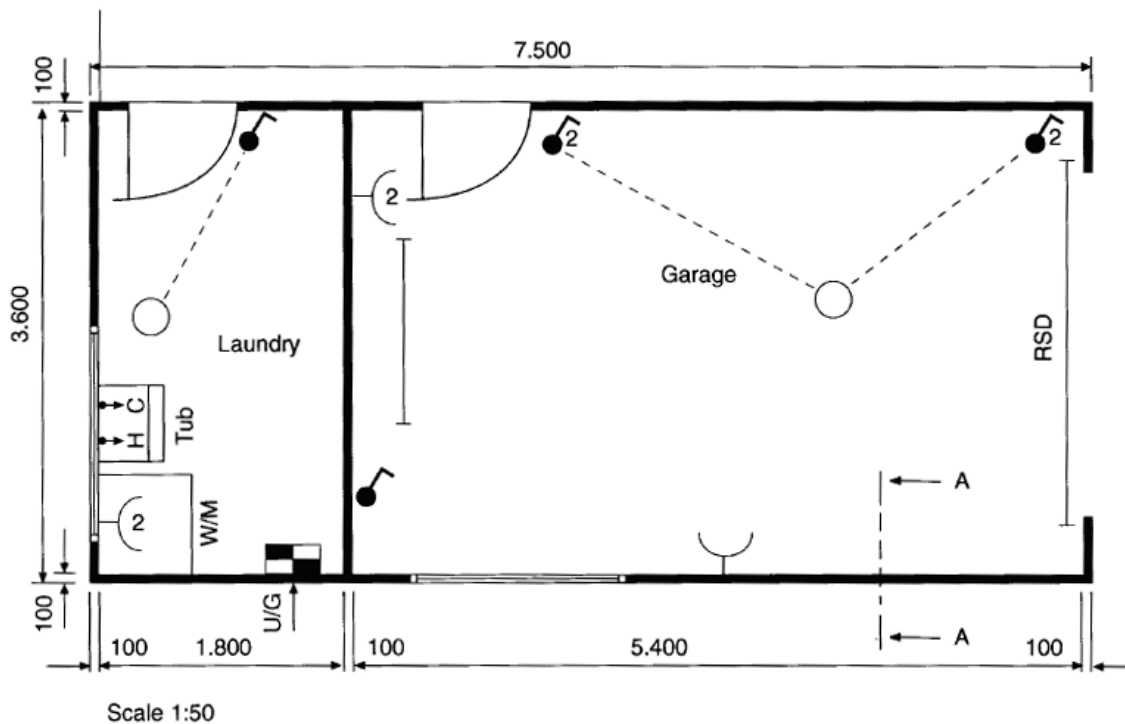



# Orthographic Working Drawings

Orthographic projection is a method of viewing an object so that a number of plane views may be drawn, each of which will include 2 of the object's three dimensions of length, breadth and depth.

Orthographic working drawings are flat views of one face of the construction project, and include plans, elevations and sectional views.

Working drawings are drawn using Third Angle Orthographic Projection.

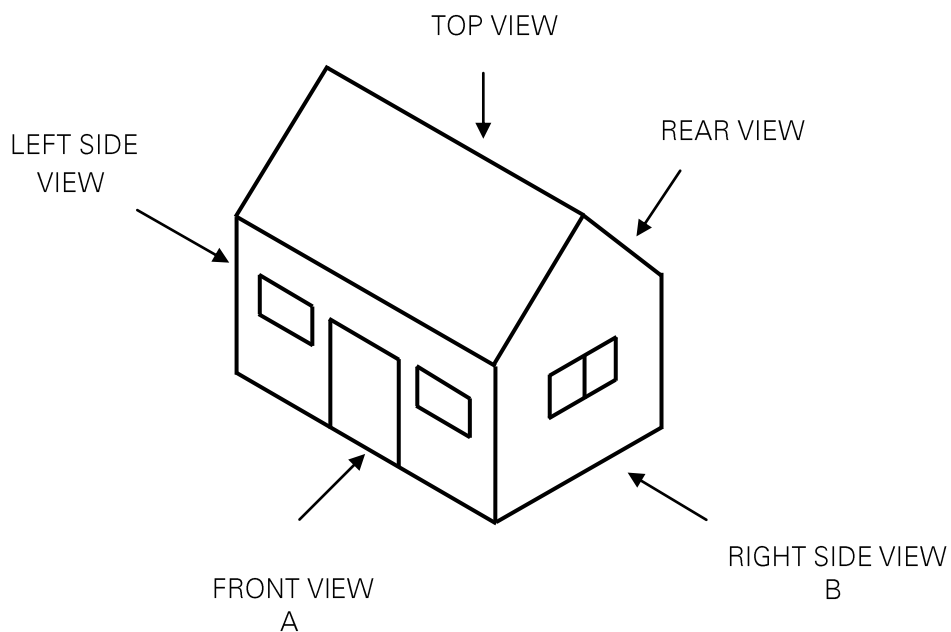
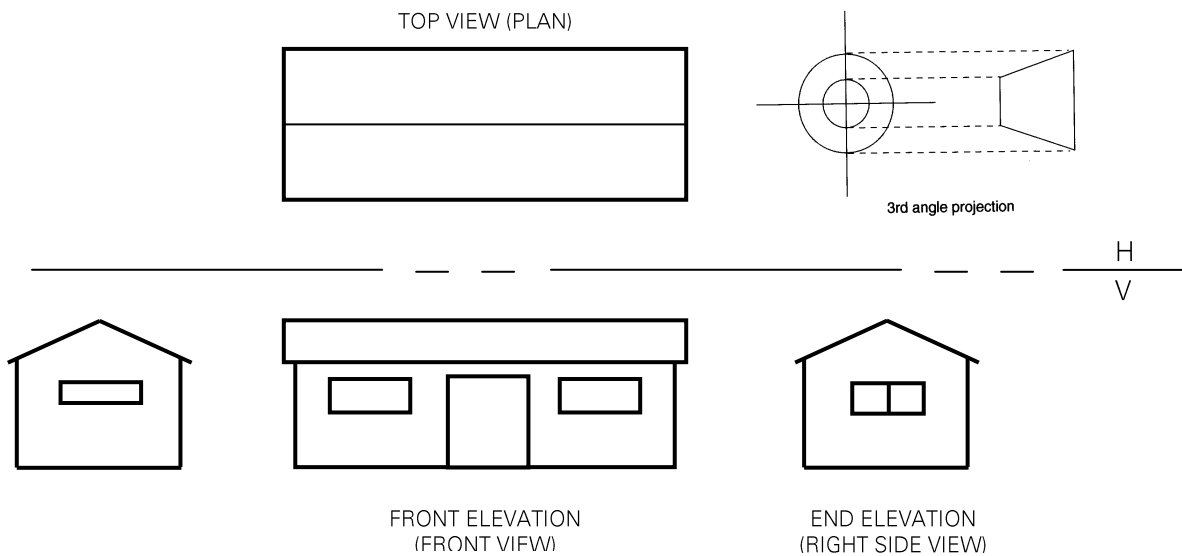

## Plans

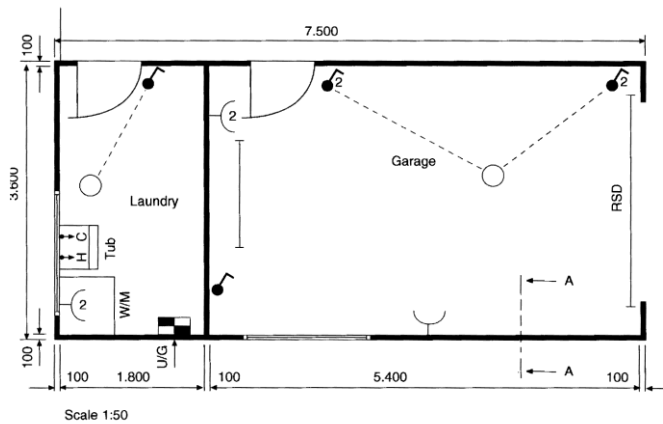

The plan is the view seen when looking directly down from above. It can provide information about:

- overall length and width;
- dimensions of parts of the construction;
- position and size of window and door openings;
- function of areas;
- position of elements such as bath, shower, etc.;
- section planes, for sectional elevations;
- scale of the plan (usually 1:50);
- location of the drawing; and
- outline of the roof shape.



Note: Refer to above diagram.

## Elevations

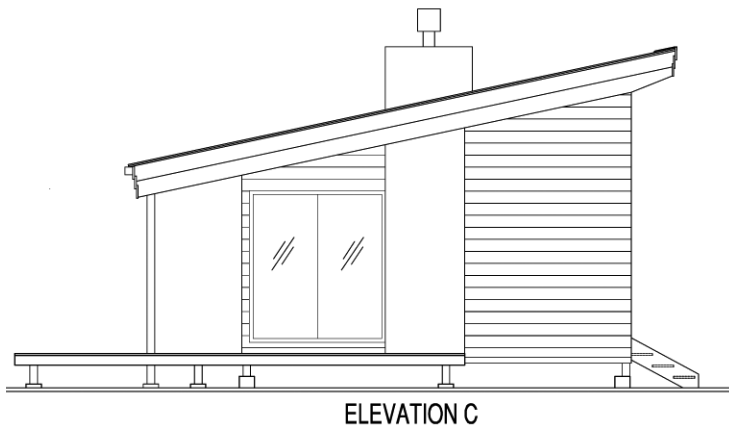

Each elevation is the view from one side of the construction when looking at it from outside. It can provide information about:

- shape of the construction from each direction;
- height of the construction;
- positions of doors and windows;
- window details and height;
- roof shape and cladding;
- type of exterior cladding and other finishing materials; and
- position of porches, decks, garages or carports.



Note: Refer to above diagram.

## Cross sections

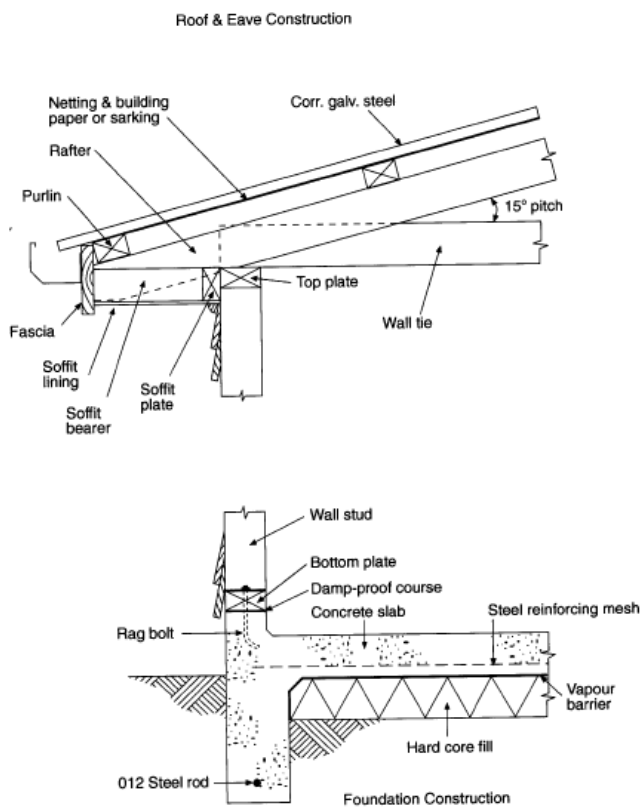

A section view differs from an elevation, as it shows the details through the construction. It can provide information about:

- foundation shape and sizes and positioning of reinforcing steel;
- sub floor construction, including piles, framing materials, bracing;
- floor and ground levels;
- roof construction and pitch; and
- window and door heights.



Note: Refer to above diagrams.

# Pictorial Working Drawings

While orthographic views will show the shape and form of an object to people who are familiar with that method of drawing, pictorial drawings are ideal for showing a realistic appearance of an object to help show untrained people what an object looks like.

Pictorial working drawings are used to provide a more realistic impression of what an object or building will look like.

Pictorial drawings can include:

- axonometric projection (isometric, dimetric and trimetric);
- oblique projection; and
- one and 2 point perspective

## Isometric drawing

The word “isometric” means equal measure, and to produce an isometric drawing it is necessary to view an object so that its principal faces are equally inclined to the viewer.

The main purpose of an isometric view is to produce a pictorial drawing which shows as much detail as possible and this must be considered when selecting the faces to be seen.

Isometric drawings are “built up” using three axes called isometric axes.

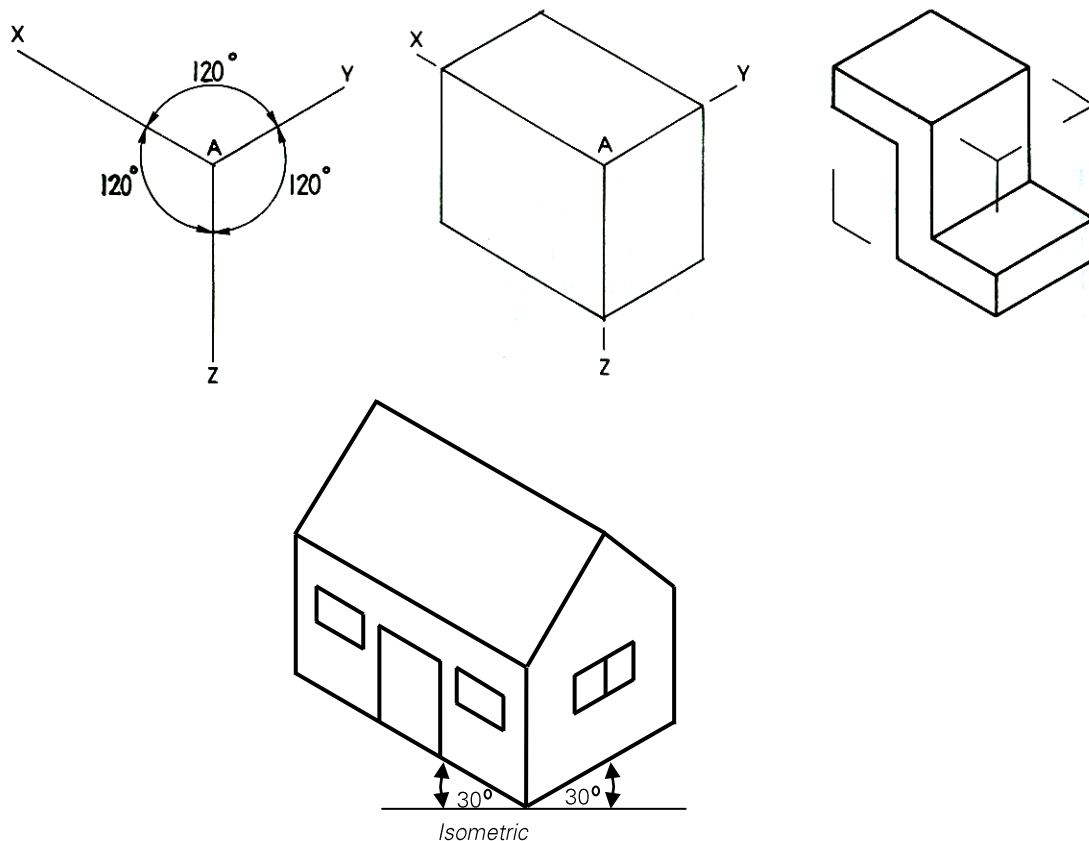

## Oblique drawing

With this type of projection, the object is viewed from an oblique angle so that the resulting view appears three dimensional.

The object is placed so that its front face is parallel to the picture plane and the view is produced by drawing parallel depth lines receding from the front view. Depth lines are usually drawn at 45, 30 and 60 deg. with 45 deg. the most common. However, any angle which shows the detail to the best advantage may be used.

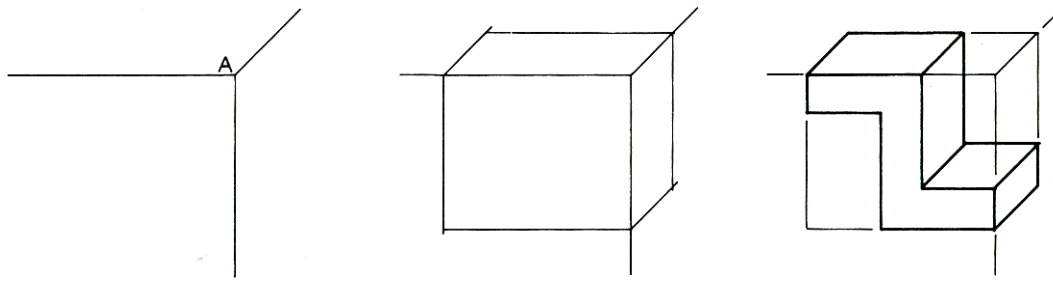

There are 2 types of oblique drawings commonly used:

- **Cavalier:** The same scale is used on each axis
- **Cabinet:** The scale on the receding axis is half the actual size. Cabinet oblique produces a more realistic view of an object.

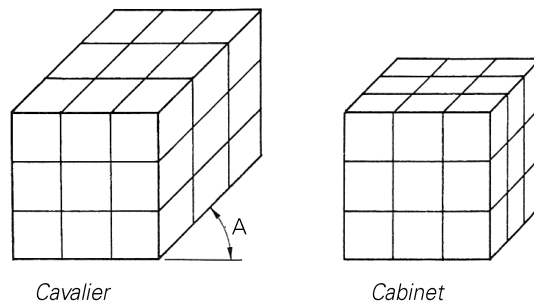

**Note:** Angle A can be 30°, 45° or 60°. The most common is 45°.

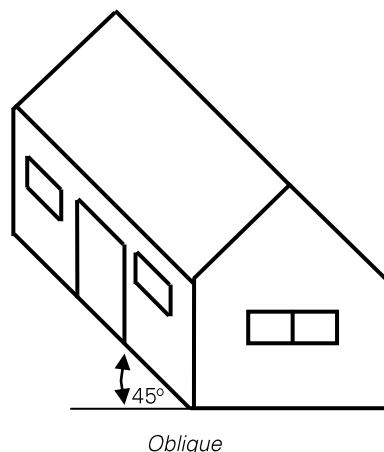

## Perspective drawing

The purpose of a perspective drawing is to produce a pictorial view of an object as it would appear to the eye. When the eye sees an object, and depending on the relative position of the eye with respect to the object, the edges will appear to converge towards a distant point.

So, in reality, objects appear to be progressively smaller the further away they are, when viewed with our eyes or through the lens of a camera. Lines parallel to each other appear to converge at a point on the horizon called the vanishing point.

All lines which are on the ground or parallel to the ground will have the same vanishing point.

The horizon will always appear at eye level. This means that, whether a person is sitting on the ground or standing on a ladder, the horizon line will be at eye level.

There are 2 types of perspective drawings commonly used:

- One point or parallel perspective: This is the simplest type of perspective to draw as the depth lines only to one vanishing point.
- 2 point perspective or angular perspective: For this method of perspective, 2 vanishing points are located on the horizon line and a different view of an object can be produced by placing it above or below the horizon line or by moving it further to the left or right. Objects that are normally above eye level are usually drawn above the horizon line while objects that normally occur below eye level will be drawn below the horizon line.

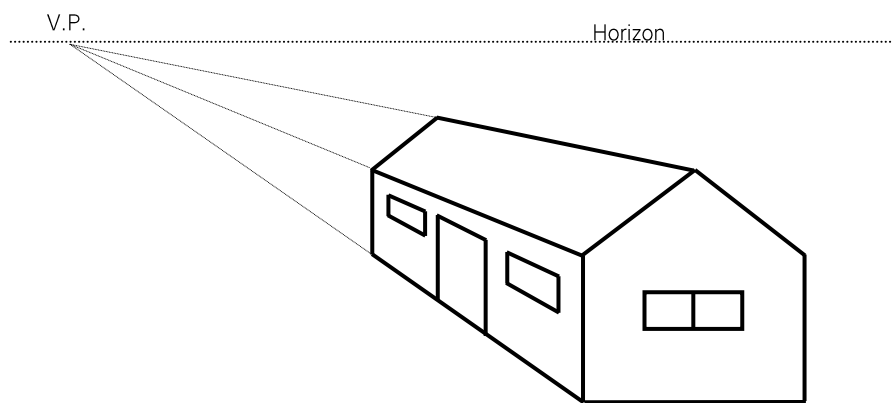

*One point perspective*

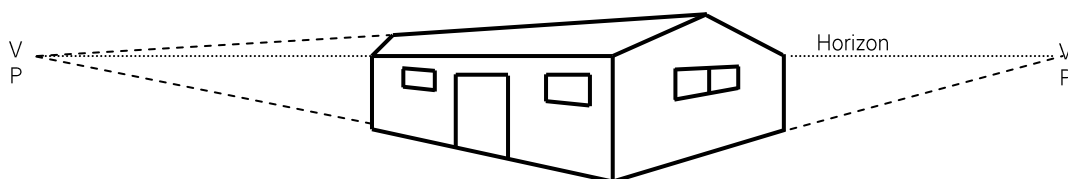

*2 point perspective*

# Drawing Equipment

Drawing equipment of good quality is essential to produce drawings of a good quality and will last for many years if looked after properly.

Be sure that when purchasing drawing equipment that it is of good quality.

When not in use, the equipment should be carefully stored away so it will not be damaged or become dirty.

The following are the five basic items of drawing equipment most often used to prepare drawings.

## Drawing boards

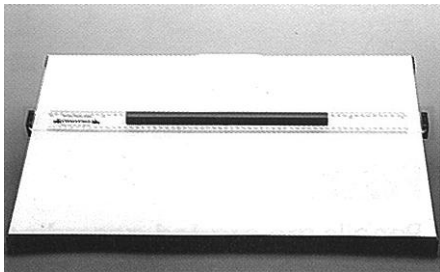

The drawing board is fundamental to producing good quality drawings. The surface must be smooth and flat and the working edge for the T-square must be true.

## Tee squares

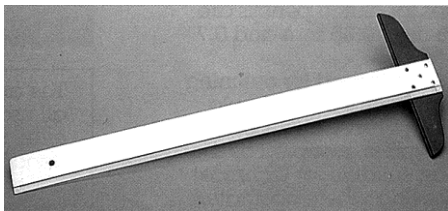

The T-square is used to draw parallel horizontal lines. It is also used as a base for set squares to draw vertical and oblique lines. The blade must be at right angles to the stock and perfectly straight. The stock must always be kept hard up against the edge of the drawing board.



## Set squares

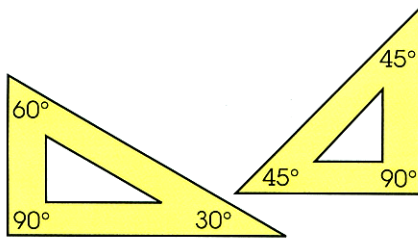

Set squares are made from clear or coloured plastic with a bevelled edge for ink work. They are placed on the T-square to draw vertical and inclined lines. The 2 set squares generally used are the 60/30 deg. and the 45 deg. They should be kept clean by wiping them regularly with a damp cloth or methylated spirits to remove the accumulation of pencil graphite (lead).

## Pencils



Pencils used to produce technical drawing must be of a high quality.

They are graded according to their hardness and blackness. Softer and blacker pencils have more graphite and will produce a darker line than hard pencils.

Hard pencils are graded from 9H, the hardest, down to 4H. They leave a sharp, faint line that does not smudge easily and used mainly for construction lines during the preparation of drawings.

Medium grade pencils range from the 3H to the softer B. The 2H and HB are ideal for finishing drawings, the HB (hard black) for lining in, and a 2H for dimensioning.

Soft grade pencils range from 2B to the softest, 7B. These are mainly used for freehand sketching, rendering (shading) and artwork. They will smudge easily and require frequent sharpening.

When sharpening pencils, trim the end opposite the grade mark to a thin taper and finish to a conical point using fine abrasive paper glued to a shaped wooden pad. This will ensure that the graphite is not transferred by the hands and onto the drawing paper and equipment. Pencils should always be sharpened well away from the drawing table.

Clutch pencils, which accept leads of various hardness, are an alternative option to a standard pencil. The retractable leads remain sharper and are less likely to be damaged.

Once the drawing has been completed, pencils should be carefully stored away in their own container where they are less likely to be damaged.

## Compass and dividers

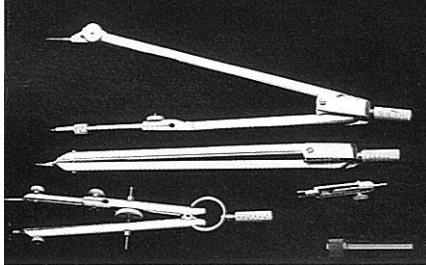

Drawing instruments can be purchased separately or more preferably as a set.

A basic drawing set will contain:

- an adjustable long leg compass;
- a small bow compass;
- a pair of dividers;
- spare leads; and
- a small screwdriver.

A compass is used for drawing circles and radii. Some compasses are equipped with both leads and points so they can also be used as dividers. The lead used in the compass should be one grade darker than the pencil being used.

Dividers are used to transfer measurements accurately from a rule onto a drawing.

Choose quality instruments that are strong and robust and store them in a case when not in use to protect them from damage.

## **Freehand Drawing**

The icon for the section header, consisting of a solid black square with a white circle inside, positioned to the left of the title.

Freehand drawing is a means of developing ideas, simple sketches often forming the basis of creative design. It is a quick, clear method of communication achieved without the use of mechanical guides.

Freehand drawing is a valuable skill to develop, especially for those students intending to work in a trade in the construction sector, as it is important to be able to communicate and develop ideas when looking for solutions to problems.

The criteria for achieving good, clear freehand drawings are:

- The drawing must clearly describe the idea or part.
- It should be in good proportion.
- Line work must be clear and neat.