



**BCATS**

BUILDING, CONSTRUCTION  
AND ALLIED TRADES SKILLS

# Fixed machinery

Learning resource

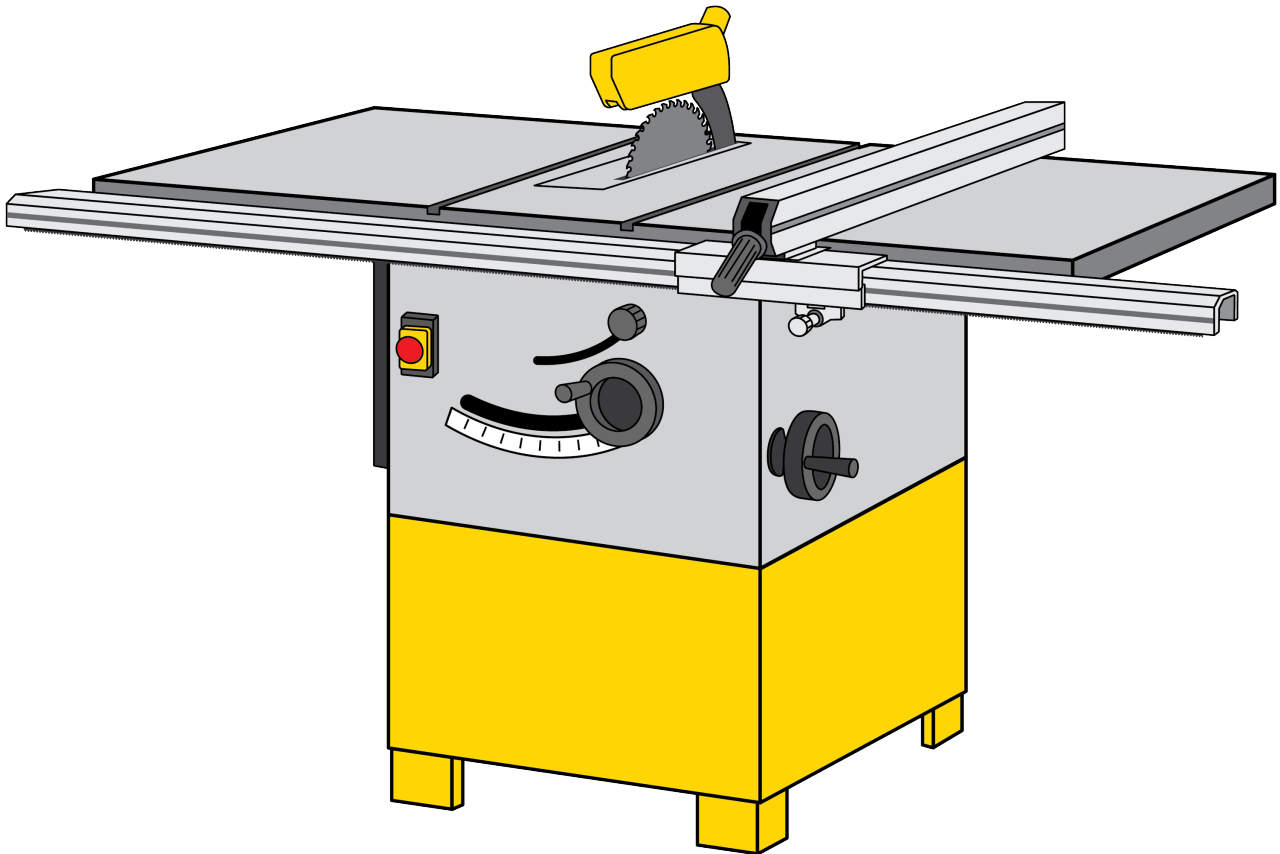

**This resource provides guidance  
for the following BCATS skill standards:**

**Level 2 - 40554**

Use fixed machinery for a BCATS project

**Level 3 - 40571**

Manage the use of tools, equipment, and machinery for a BCATS project

**BCITO**  
He Hunga Hanga Mātou  
building people



# Contents

> <b>Introduction</b>	4
> <b>Safety with fixed machinery</b>	7
Emergency cut-off equipment	12
> <b>Types of fixed machinery</b>	13
Cutting machinery	14
Planing and finishing machinery	22
Drilling machinery	25
Shaping machinery	28
Computerised machinery	31

## **Building and Construction Industry Training Organisation (BCITO)**

Level 5, 234 Wakefield Street  
PO Box 2615  
Wellington 6140

0800 422 486

[www.bcito.org.nz](http://www.bcito.org.nz)

© 2026 BCITO

All rights reserved.

No part of this work may be reproduced, adapted, modified, copied, or transmitted in any form or by any means, including by way of example only, written, graphic, electronic, mechanical, reprographic, photocopying, recording, taping, or information retrieval systems, without the written permission of the publisher.

# Introduction

Working with tools and machinery is both enjoyable and rewarding as you turn raw materials into something useful and lasting.

There is a lot of different fixed machinery available and this resource would be huge if it included every one of them. We have included the machinery you would most often use while working on your Building, Construction, and Allied Trades Skills (BCATS) projects.

You'll learn:

- what different machines there are, and what they are used for
- how to look after the machinery you use
- which PPE you should use with different machines.



**Fixed machinery can be very dangerous.**

**Depending on your school's policy, you might not be able to use some of the fixed machinery included in this resource. Or you might only be allowed to use it under close supervision.**

**Your teacher will tell you which machines you can use. Watch how they set up and use them.**

# Operating fixed machinery



- ONLY operate fixed machinery after first being trained.





- Look after the machinery you use and remember to keep it clean.



- Each machine has standard operating procedures and safety rules that must be followed to reduce the danger to you and others.

There are a few things to think about before you get started.

- Do you know which machinery you need to use for your project? 
- Have you checked the machinery is safe and ready for use? 
- Have you been trained to use the machinery properly? 

# Safety with fixed machinery

Apart from using personal protective equipment (PPE), you can keep safe by selecting and using fixed machinery properly.

- Even if you are making a quick cut, always follow safety rules for fixed machinery. Ignoring them just once can cause very serious injuries.
- Do not use any damaged machinery (and report any damage you see).
- Never run your fingers across a blade to check how sharp it is.

You have a responsibility to ask your teacher for guidance if you're not sure how to use machinery properly.

# Setting up

It is useful to prepare all machinery you'll need before you start working on a task. You should only work in a tidy, well-lit machinery area that you have permission to enter.

---

## Before using fixed machinery

- Read and follow the manufacturer's instructions.
- Check the power supply and make sure all electrical leads have up-to-date inspection tags.
- Clear the floor around the machine, removing anything that could trip you up.
- Check that all safety guards are in the right place and secure (see below).
- Make sure the material you will be machining is free of any fasteners (e.g. nails).
- Choose and wear appropriate PPE (i.e. safety goggles, dust mask, earmuffs, covered shoes).

---

## While using fixed machinery

- Avoid distraction and stay focused.
- The stop button must work and be easy for you to reach.
- Stand to the side of the machine when starting it.
- Wait for the machine to reach full speed before starting your work.
- If you feel like you need to force the material through the machine, stop and ask your teacher for help.
- Turn off the machine before adjusting or clearing waste.
- Turn off the machine before leaving your workstation.
- Keep the work surface area free of scraps and offcuts.

---

## After using fixed machinery

The overall maintenance of machinery will be the responsibility of your teacher. You need to tell them if you find anything that needs repair or replacing.

Below are some cleaning and care responsibilities you might be responsible for.

- Make sure all machinery that has been used is cleaned down to remove dust and debris.
- Check that cutting blades are sharp and in good condition.
- Rub metal components, including screws and table slides, with light machine oil to prevent rust.
- Apply grease to bearings if required.
- Make sure emergency stop buttons are working.
- Inspect electrical cords and plugs for damage.

## Hazards and controls

Every machine has its own hazard, and every hazard can be controlled or have the risk minimised. Below are some common examples.

Hazard	Potential harm	Control(s)
Long hair getting caught in machinery	Hair ripped out or pulled into the machine	Tie long hair back
Ties, scarves, loose clothing, jewellery getting caught in machinery	Choking or being pulled into the machine	Wear close-fitting clothes Take off jewellery before using machinery
Fast-moving blades, bits, or wheels	Material being thrown at speed	Wear appropriate PPE (i.e. safety goggles, dust mask, earmuffs, covered footwear)
Dust	Harm to the lungs	
Loud noise	Hearing loss	
Dropped items	Injury to feet	
Sharp saw blades	Cuts to hands and fingers	Keep your fingers away from the blades
Gloves getting caught in machinery	Crushed fingers	Use bare hands when operating rotating machinery
Exposed belts, pulleys, blades, and cutter heads	Serious injury	Fasten all guards correctly in position
Starting the machine accidentally while you are setting it up	Serious injury	Isolate the machine from the power supply when setting up/adjusting

### Guards

Fixed machinery will often have a guard or an in-built safety measure. Guards are essential for protecting you against contact with moving parts, flying debris, kickback, and noise.

- Never remove guards during use.
- Regularly inspect for damage, secure attachment, and smooth action.
- Clean and oil moving parts to keep spring-loaded guards work properly.



## Eye protection

Flying debris, sawdust, and chips can cause severe eye injuries or permanent blindness. Safety glasses and safety goggles are available in clear and a range of colours. All New Zealand certified safety eyewear is tested and approved for medium impact protection.

### Recommended PPE

**Safety glasses** - are lightweight and ideal for general use.

**Goggles** - provide better side protection and seal around the eyes which is better for dust-heavy environments.

**Face shields** - can be used in addition to safety glasses for maximum protection when operating high-risk machinery.



## Ear protection

Fixed machinery is very noisy and can cause permanent hearing loss over time.

### Recommended PPE

**Earplugs** - hugely reduce noise when worn properly. They are relatively cheap and effective for short work sessions.

**Earmuffs** - offer more comfort and better noise reduction for prolonged use.



## Dust masks and respirators

Inhaling fine wood dust can lead to respiratory issues, allergies, or even chronic lung disease.

### Recommended PPE

**Dust masks (N95)** - are good for basic protection against large particles during sanding or cutting.

**Respirators (half-mask with filters)** - P100 filters are needed for finer particles or fumes from finishes and chemicals.



## Footwear and gloves

Dropped tools, sharp materials, and hot surfaces can cause serious injuries to hands and feet in a workshop.

### Recommended PPE

**Sturdy footwear** - fully enclosed, hard-wearing shoes help protect feet from falling objects and sharp debris. Steel caps should be worn when working with heavy materials.

**Protective gloves** - reduce the risk of splinters, cuts, and burns when handling rough, sharp, or hot materials.

Gloves must **not** be worn when operating rotating machinery, as they can become entangled and cause severe injury.



# Sawdust

Using most fixed machinery will always produce some sawdust. This might seem harmless, but it can create health and safety risks if not handled properly. Here's what you need to know about sawdust.

---

## 1. Respiratory dangers

Fine dust particles can irritate the nose, throat, and lungs. Long-term inhalation can lead to serious lung infections.

Certain hardwood dusts, like beech or oak, are classified as carcinogenic, increasing the risk of nasal and sinus cancers.

---

## 2. Allergic reactions

Treated timber and some wood varieties, like cedar or teak, contain chemicals that can cause:

- > skin rashes
- > eye irritation
- > breathing issues.

---

## 3. Fire hazard

Sawdust is highly flammable. Dust that builds up near heat sources or sparks can cause fires or explosions in workplaces.

---

## 4. Environmental and cleanliness issues

Dust can settle on tools and clog them up. On the floor it creates slippery surfaces, increasing the risk of accidents.

## How to stay safe

**Wear PPE** - dust mask or respirator, safety goggles.

**Use dust collection systems** - attach dust bags or vacuum extractors to tools.

**Ventilation** - keep your workspace well-ventilated.

**Regular cleaning** - sweep or vacuum often.

**Avoid compressed air** - blowing dust spreads it into the air.

## Emergency cut-off equipment

This is a manually operated safety device designed to stop machinery quickly if there is a hazardous or unexpected situation that could be harmful to the person using the machine.



### Where are emergency stop buttons needed?

The Health and Safety at Work Act 2015 and WorkSafe New Zealand provide guidance on machinery safety.

In workshops, emergency stops are typically found on:

- saws (table, band, panel)
- lathes and CNC machines
- presses and forming equipment
- conveyors and automated systems.

School technology rooms and training workshops will also have emergency stops that will stop the whole room.

Emergency stops are signposted with green or red signs. Your teacher will show you how the system works in your workshop.



### What does the device look like?

Most often, the device will be a large red button set on a yellow background. These buttons are generally mounted on the wall and should be clearly visible and easy to reach. In large workshops there might be more than one button.

Some workshops might have other kinds of devices like ceiling mounted wires that can be pulled in an emergency.



### How does it work?

When the emergency stop is pressed:

- dangerous machine movement must stop immediately
- it must latch in the OFF position
- the machinery must not restart automatically when released.

**Emergency stops are not a replacement for guards or safe operating procedures and should not be used as a routine stop/start button.**



# Types of fixed machinery

Fixed machinery can be grouped by purpose, such as cutting, planing, drilling, or shaping.

The construction industry includes many different trades, each with its own specialist tools. If your project requires any of these, your teacher will introduce them to you.



# Cutting machinery

In a school workshop, fixed saws are mounted in place rather than being handheld. They're designed for accuracy, repeatability, and safer use (when operated properly).

Before you start the saw, test the position of the blade to make sure it's sitting on the waste side of your measurement marks.

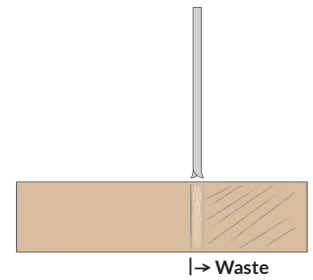

## Cuts

Different cutting techniques are used in woodworking depending on the direction of the cut and the result you want.

### Crosscutting

This refers to cutting across the grain of the wood. This is most commonly done when cutting timber to specific lengths.

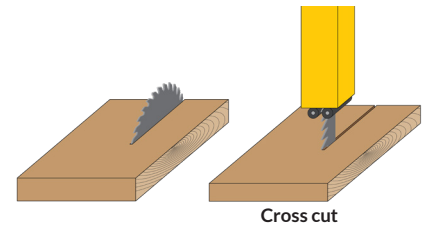

### Ripping

This refers to cutting along the grain of the wood. This is used when you need to reduce the width of a board.

Usually done on a table saw or band saw.

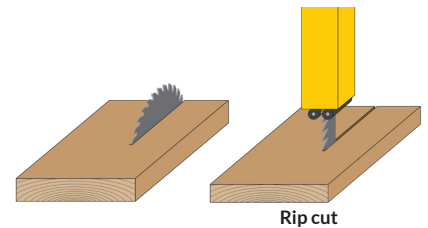

### Re-sawing

This is a variation of a rip cut when cutting a board along its width while standing on its edge. Re-sawing is used when cutting a big piece of timber into thinner boards.

Usually done on a band saw because of the larger cutting range.

- For best results use a deep blade with large teeth. Make sure the blade is tracking through the guide wheels properly.
- Be aware of blade drift when re-sawing.

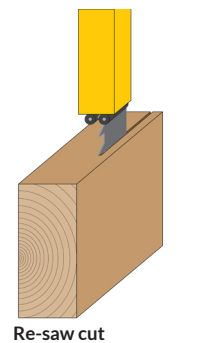

### Bevels and angles

When making angled cuts like mitres, bevels, or chamfers, the blade or table can be tilted and used with a fence on the lower side of the cut.

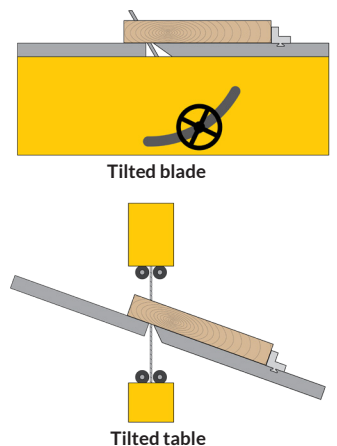
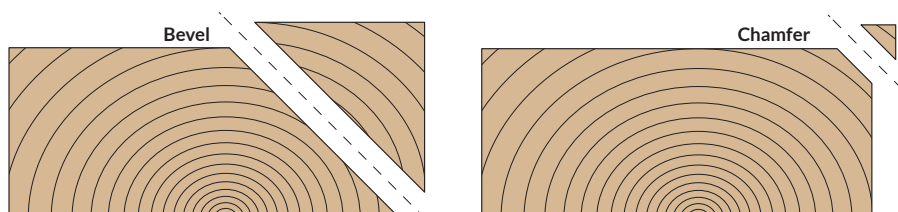

## Cutting curves

Using a fine bladed saw is ideal for cutting around corners. The band saw and scroll saw are both used for this kind of work.

**The band saw** - is better suited to larger, more gradual curves and thicker materials. Changing blades on the band saw take a lot more time and care to set up correctly.

**The scroll saw** - is smaller and works well with fine details. The blade is simple to change which makes it versatile if you are making internal cuts or changing materials.

In both cases, steady control is important to achieve clean, accurate curves without forcing the wood. Most of your cuts will follow pencil lines with the blade cutting on the waste side of the line.

### When making curved cuts:

- use a fine-tooth blade with shorter depth to allow for more flexibility
- drill relief holes or make a series of smaller straight cuts on the outside of tight curves to help reduce tension on the blade
- always plan your cut so you don't have to back the blade out.



### When making interior cuts:

- drill a pilot hole big enough to fit the blade
- remove the scroll saw blade, thread it through the pilot hole, and reconnect the blade
- reset the blade tension, hold-down foot, and any guards.

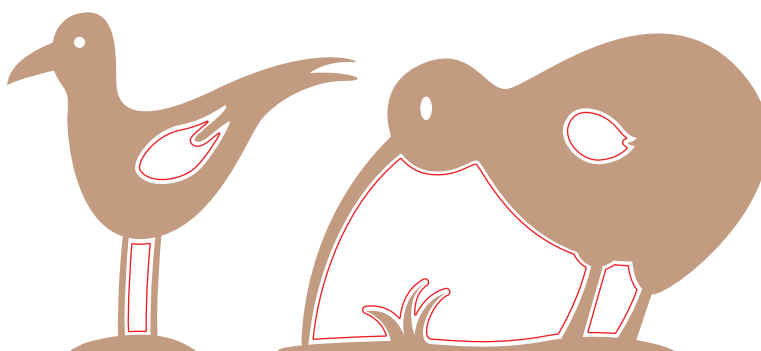

## Band saw

A band saw works by using a continuous loop of blade that runs over two or more wheels to cut material in a smooth, controlled way.

It is used to make straight and curved cuts in timber, engineered wood products, and plastics. It can cut through quite thick materials with minimal waste. On some saws, the table surface can be tilted to make angled (bevel) cuts up to 45 degrees.

Your workshop might have a full size or benchtop band saw. They will both work in a similar way but the adjustment knobs may be in different places from those in the picture below. Your teacher will explain how to use the one you have.

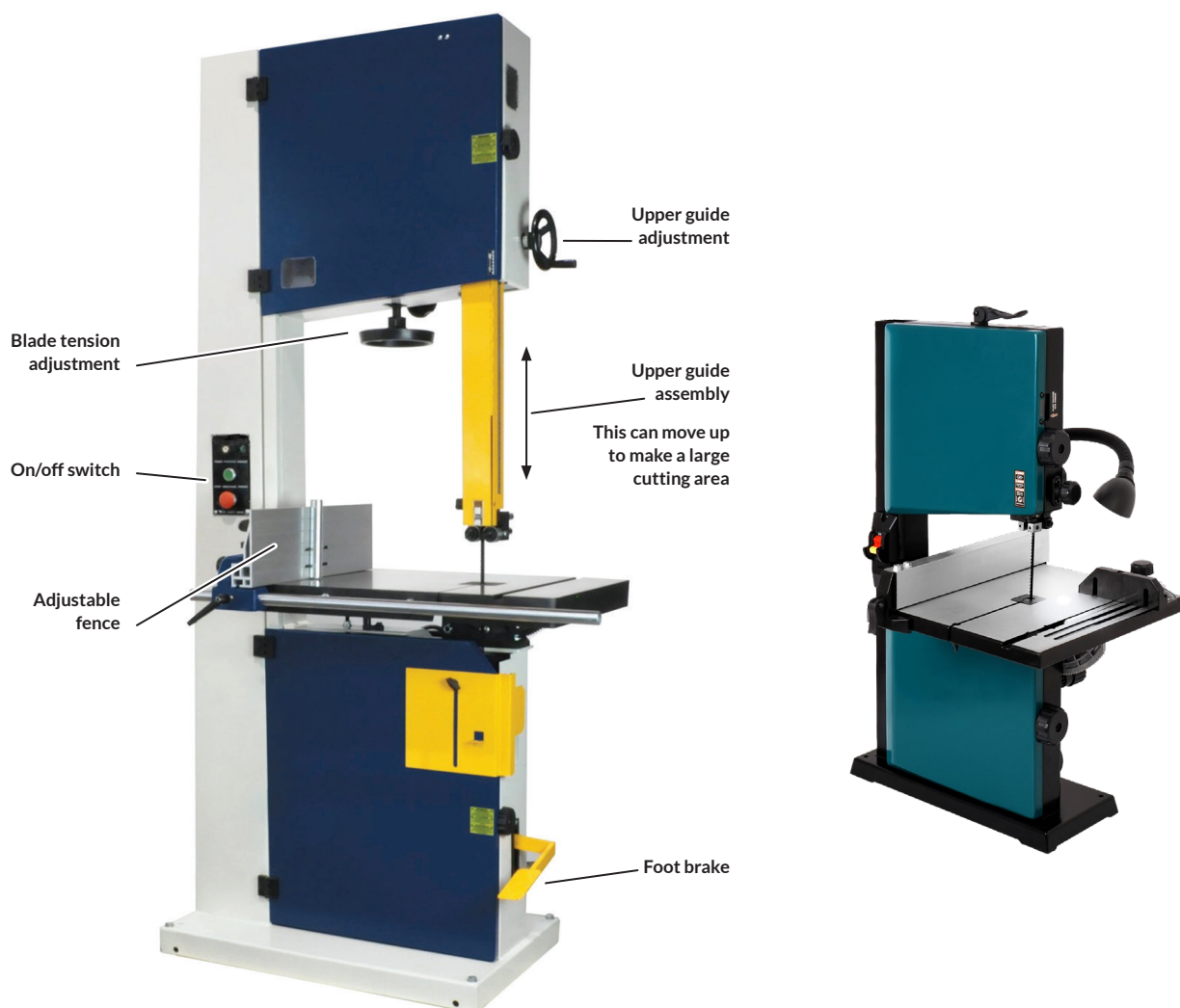

### Tips for use

- Make sure all guards are in place. Never use a band saw if the blade side guard is missing.
- Make sure the blade is right for the job and properly tightened.
- Adjust the height of the upper guide to about 10mm above the workpiece.
- Feed the workpiece at a slow, even speed letting the saw do the work. Don't force the wood into the blade.
- Watch out for the blade drifting off course on long rip cuts.
- Avoid twisting the blade when cutting tight curves.

## Scroll saw

A scroll saw is a precise cutting machine used in woodworking. It has a thin blade that moves up and down very quickly, allowing you to make fine, detailed cuts. It is especially good for curves and intricate designs in wood, plastic, or thin metal.

The scroll saw is relatively easy to control and considered safer than many other saw machines because of the small blade. This makes it great for beginners learning precision skills.

Scroll saws are ideal for:

- intricate patterns and shapes
- tight curves and sharp turns
- decorative work (signs, lettering, ornaments).

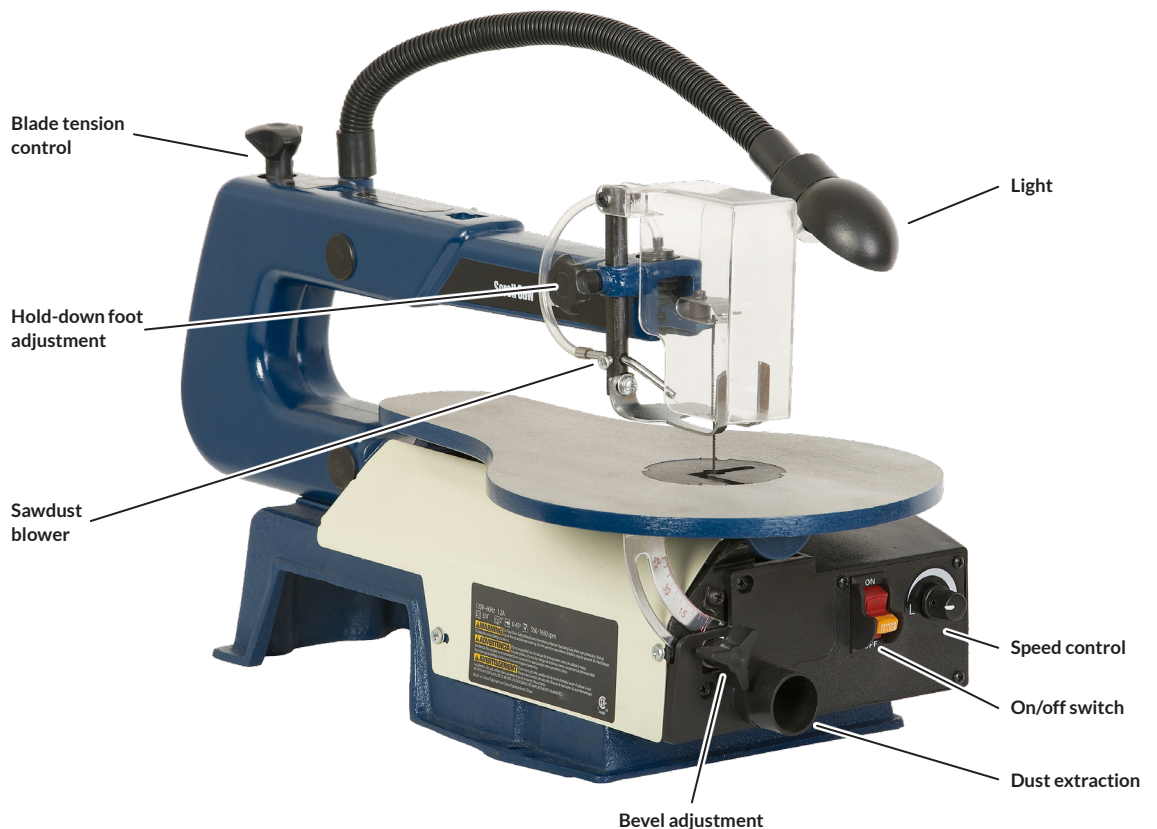

## Tips for use

- Keep fingers clear of the blade path.
- Use the hold-down foot when possible.
- Unplug the machine before adjusting the blade.

## Table saw

Also known as a bench saw, the table saw has a circular blade mounted under a flat table surface. The blade can be moved up through the surface and set to different heights and angles.

This is a powerful tool used to make straight and angled cuts in timber and other materials with a high level of accuracy.

Table saws will sometimes be used with a sliding outrigger table to cut large sheet materials. This saw is called a dimension saw. They will both work in a similar way but the adjustment knobs may be in different places from those in the picture below. Your teacher will explain how to use the one you have.

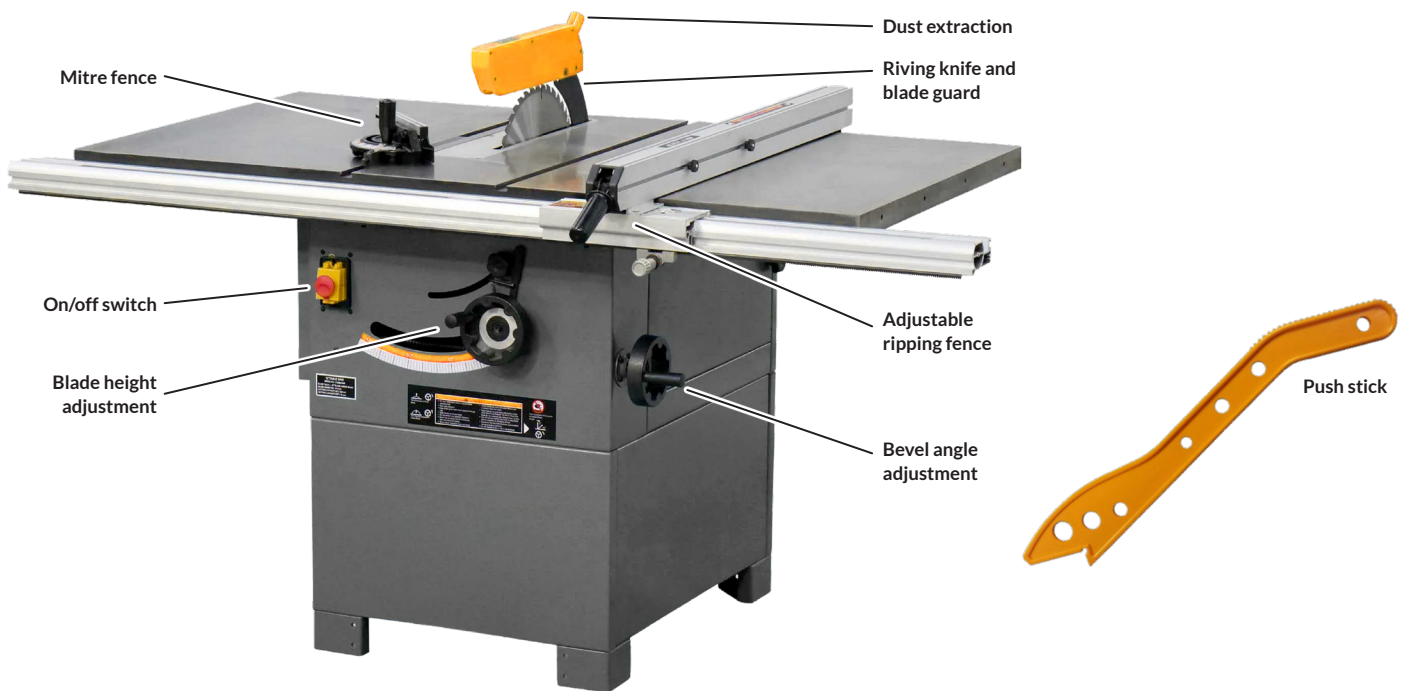

### Parts of a table saw

**Adjustment wheels** – used to raise or lower the height of the blade and tilt the angle of the blade from vertical up to 45 degrees.

**Ripping fence** – a guide or fence that is positioned parallel to the blade. It can be adjusted and locked in place.

**Mitre fence** – a guide or fence that slides forwards in a groove parallel to the blade. It is used for crosscutting timber at 90 degrees or to cut plus or minus 45 degrees.

**Riving knife** – also called a fin or splitter. It sits just behind the saw blade to stop the timber from closing on the blade and kicking back toward the operator.

**Blade guard** – a shield that covers the top of the blade. It will generally be connected to the riving knife and moves up and down with the blade. The guard should be adjusted close to the wood to protect you from the blade, flying splinters, or wood that might lift off.

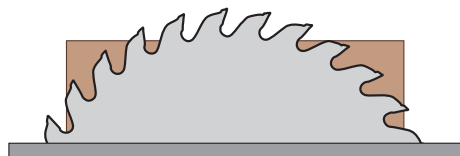

To make a smoother cut, set the height so that only the teeth of the blade are exposed on the top side of the material.

### Tips for use

- Make sure the riving knife and blade guard are in place. Never use a table saw if the blade guard is missing.
- Adjust the height of the blade to about 10 – 15mm above the workpiece.
- Feed the workpiece at a slow, even speed letting the saw do the work. Don't force the wood into the blade.
- Keep your fingers away from the cutting line and use a push stick when cutting small pieces of timber.
- It's a good idea to have a helper support long material at the end of the cut as it leaves the back of the saw.



### IMPORTANT

Using a push stick with a table saw is an essential safety practice. It keeps your hands and fingers away from the blade while guiding the material through the cut.

Always use a push stick when the distance between the blade and the fence is less than the recommended safe distance (about 300mm).

**IMPORTANT**

The use of these machines may be restricted to the teacher only.



## Compound/mitre saw

Also known as a drop saw, the mitre saw has a circular blade mounted on a sliding arm. The blade can be adjusted to tilt and pivot. This allows you to cut a larger range of angles in a single action.

Mitre saws are used mostly for general crosscutting work, commonly when cutting mitres, bevels, or grooves.

On a standard mitre saw the base table will be used in the fixed central position at 90 degrees but can pivot around to the left or right. There are normally a few preset stops every 15 degrees. Some saws will only be able to pivot up to 45 degrees and others might go round to 60 degrees.

On a compound mitre saw the blade arm can also be tilted up to 45 degrees to the left or right.

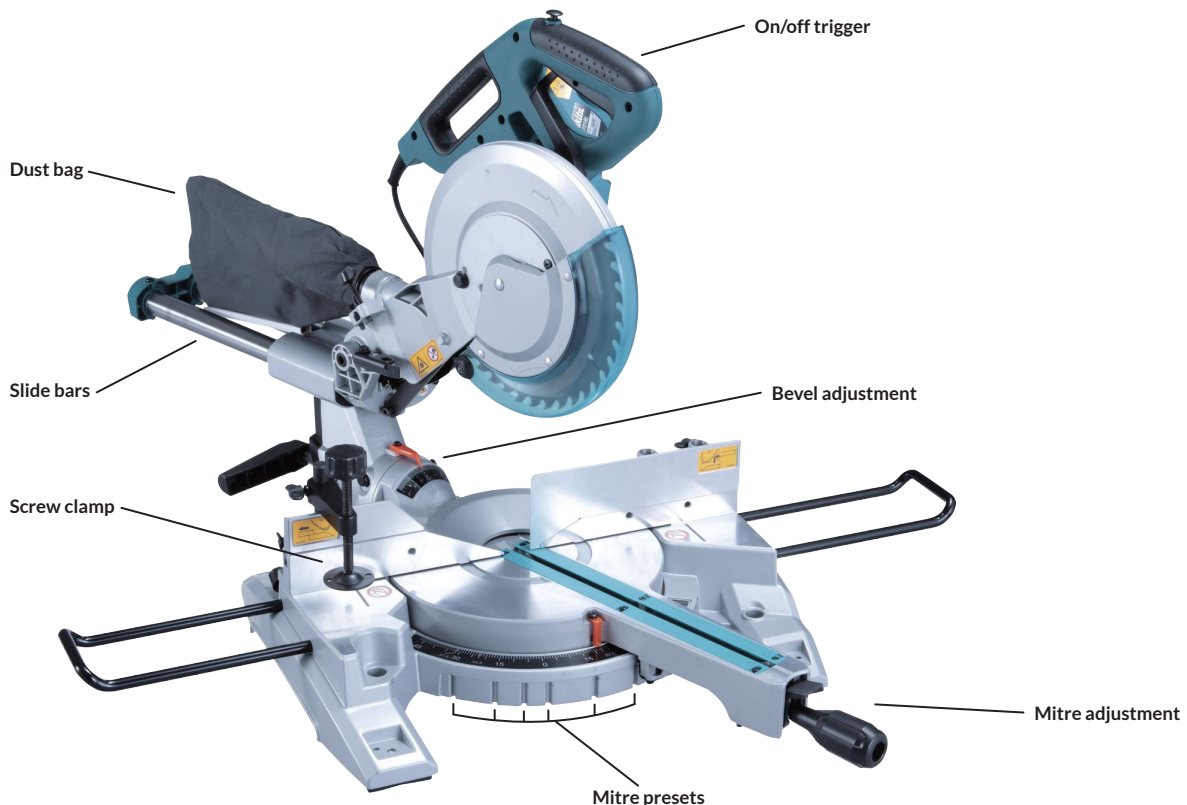
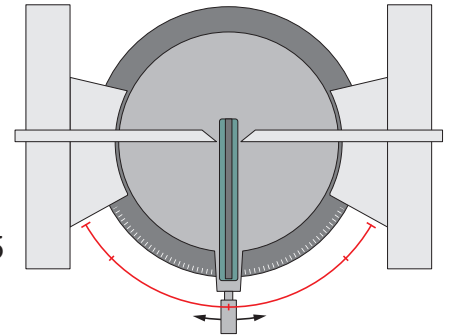

### Tips for use

- Make sure the guard is working properly. Never use a mitre saw if the blade guard is missing.
- Secure the workpiece before cutting.
- Lower the blade smoothly onto the timber. Slide the blade back through the timber while cutting.
- Release the trigger and wait for the blade to stop before raising the saw. This will prevent damage to the cut surface.

## Table-mounted router

This is a woodworking station where a handheld electric router is mounted upside down beneath a flat table surface. The router bit will poke up through the table at the height set for your desired cut.

The table also has an adjustable fence to give the operator more ability to set up and make repeatable cuts when shaping and profiling timber.

Common uses include cutting decorative or structural edges, forming rebates and grooves, trimming laminates, making raised panels, and cutting joinery such as tongue and groove or box joints.

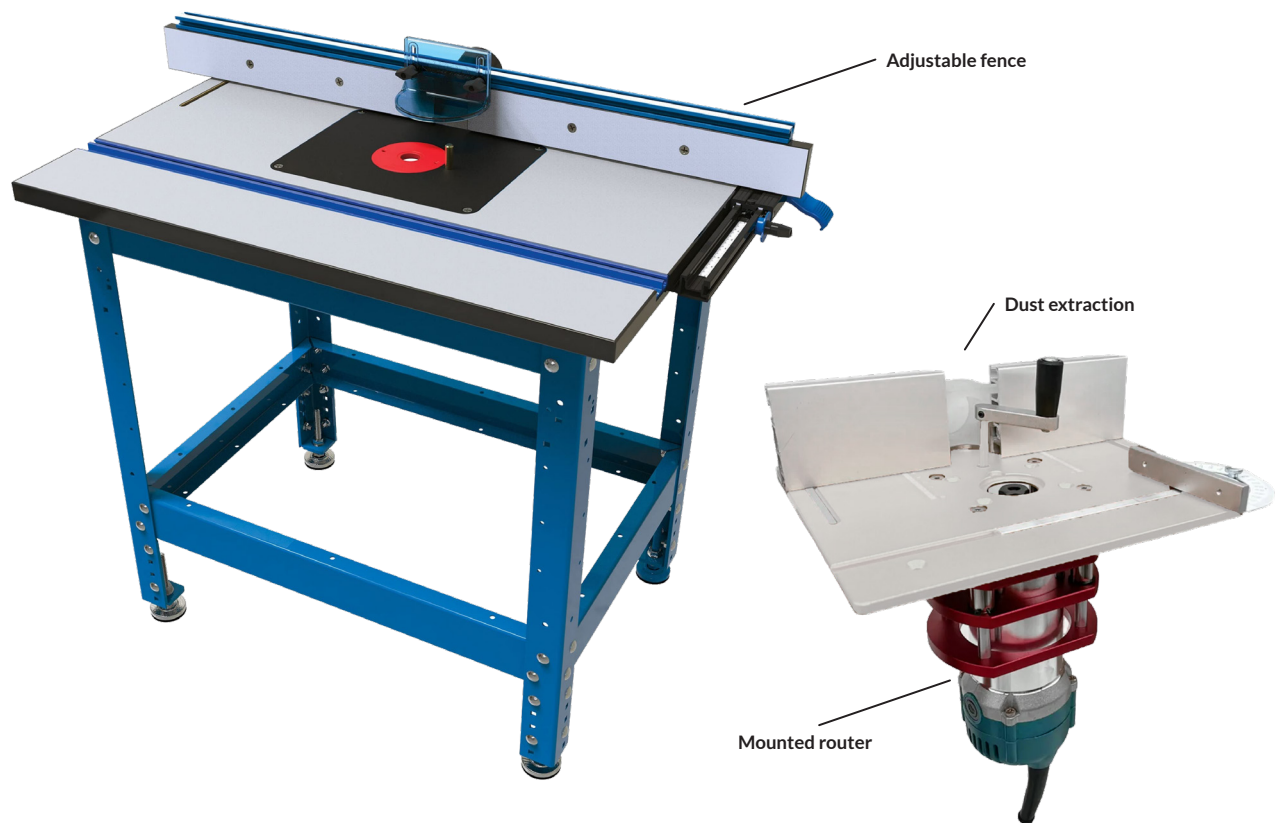

### Tips for use

- Make sure the router bit is sharp, clean, and securely tightened, and that the fence is square and locked in position.
- Keep your hands well clear of the bit. Push sticks, push blocks, and featherboards are essential for control.
- Always feed the timber against the rotation of the bit.
- Dust extraction is important with router tables, as the bit throws waste upward.
- Never adjust the bit height, fence, or router while it is running. Wait for the bit to come to a complete stop before removing offcuts or reaching near the cutter.

# Planing and finishing machinery

## Surface planer

This has a rotating cutter head mounted under the table surface. The height of the infeed table can be adjusted up or down to control how much material is removed from the timber.

It is used to dress rough-sawn timber by creating one flat face and/or one straight, square edge. This provides a reference face before thickening.



The fence supports the timber edge and can be tilted on some machines to cut bevelled edges or chamfers.

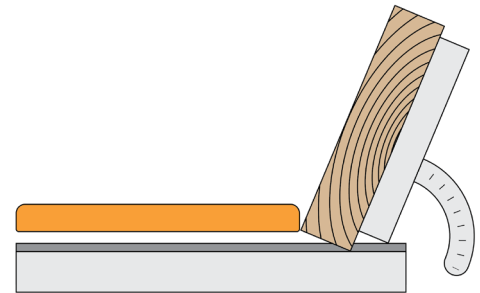

Set the blade to the same height as the outfeed table. The infeed table is lowered to set the depth of the cut.

For a smooth clean finish cut about 0.25 – 0.5mm per pass. Cutting more than 1mm increases the risk of kickback, damaging the cutter head, or loss of control.

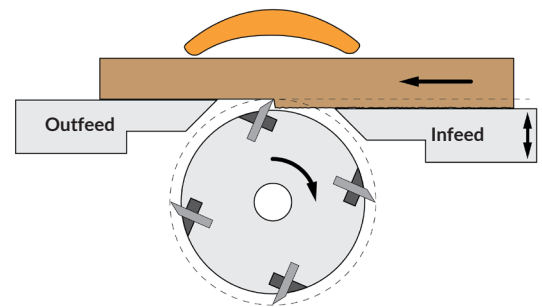

### Tips for use

- Check timber for nails, screws, staples, or loose knots.
- Only plane timber that is longer than 300mm.
- Adjust the fence and bridge guard so the full width of the timber passes over the cutter head.
- Only feed timber along the grain. Planing across the grain will damage your timber.
- Make multiple light cuts to slowly shave timber down. Avoid heavy cuts as they can strain the motor.
- Stand to the side, not directly in front or behind in case of kickback.
- Use a push stick or push plate when possible, to keep your hands clear of the blade.



## IMPORTANT

The use of these machines may be restricted to the teacher only.

### Thicknesser

This works much the same as a surface planer except the blade is mounted above the material and machine bed. The bed can be adjusted up or down to set the finished thickness.

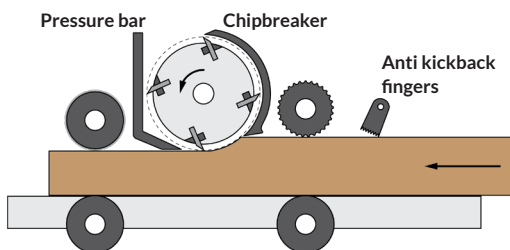

Timber is fed through automatically by rollers as the cutter removes material from the top face only.

A chip breaker and pressure bar help to make sure the cut is clean and parallel to the bottom side of the board.



Used together in sequence, the two machines allow timber to be prepared accurately and safely.

- A surface planer is used first to flatten one face of a piece of timber and square one edge.
- Once one face is flat, the timber is then passed through a thicknesser, which makes the opposite face parallel and brings the timber to an even thickness.

Some modern combination machines can perform both surface planing and thicknessing by changing the table setup, but the same preparation steps and safety principles still apply.

## Sanders

Bench-mounted disc and belt sanders are used to smooth, shape, and finish timber, metals, and some plastics.

They are ideal for refining edges, curves, and end grain after cutting.

Here are some common uses for each type of sander.

### Disc sander

- Squaring the ends of timber pieces.
- Sanding end grain cleanly.
- Refining small components and cleaning up angles using the table mitre.



### Horizontal belt sander

- Removing saw marks after using a band saw or table saw.
- Smoothing and squaring long, flat edges of timber.
- Levelling glued joints or laminations.



### Bobbin sander

- Smoothing and squaring curved edges.
- Sanding inside curves or holes.
- Refining the finish of decorative designs cut on the band saw or scroll saw.



### Tips for use

- Check the sanding surface is in good condition and the table is set correctly before use.
- Keep fingers clear of the sanding surface; use a push block or jig for small pieces.
- Only sand one piece of work at a time.
- Make sure the timber is securely positioned against the cross fence or table before it meets the abrasive belt or disc
- Sand on the downward-moving side of the disc or belt to avoid kickback.

## Drilling machinery

Fixed drilling machines are designed for straight, controlled drilling, so drill bits that stay centred and cut cleanly without grabbing are ideal.

### Twist drill bit

Most common type.

- Used for wood, metal, and plastic.



### Brad point bit

Designed for wood.

- Has a sharp point for accurate positioning.
- Makes a clean entry hole with less tear-out.



### Countersink and counterbore bit

For preparing neat fixing holes for screws.

- The countersink can be moved down the main bit to adjust the depth.



### Forstner bit

Creates clean, flat-bottom holes in wood.

- Excellent for wide shallow holes in joinery work.
- Must be run at slow speed.



### Spade bit

For large holes in wood.

- Must be run at slow speed.
- Has a higher risk of grabbing if not set up properly.



Some types of drill bits are unsuitable for use on a drill press. The following bits are often restricted and should only be used by a teacher.

### Auger bit

The screw tip will pull itself into wood and grab. This can cause the workpiece to spin or break.



### Hole saw bit

These bits are prone to sudden grabbing and can overheat when not used properly.



## IMPORTANT

Certain materials and drill bits will work better at different speeds.

Adjusting the speed of the drill can be tricky. Your teacher will probably need to be responsible for this.

## Horizontal borer

Also called a dowel borer, this machine is used to drill accurate, straight holes for dowel joints.

In cabinetry construction, dowel holes must line up accurately to make sure joints are strong and tidy. This is especially important for edge-to-edge joints, general frame joints, and door components such as rails and stiles.

Some horizontal borers can run multiple spindles at the same time. This lets you drill repeatable sets of dowel joints.

Older machines are manually operated but many newer machines work automatically, controlled by a pneumatic foot pedal.

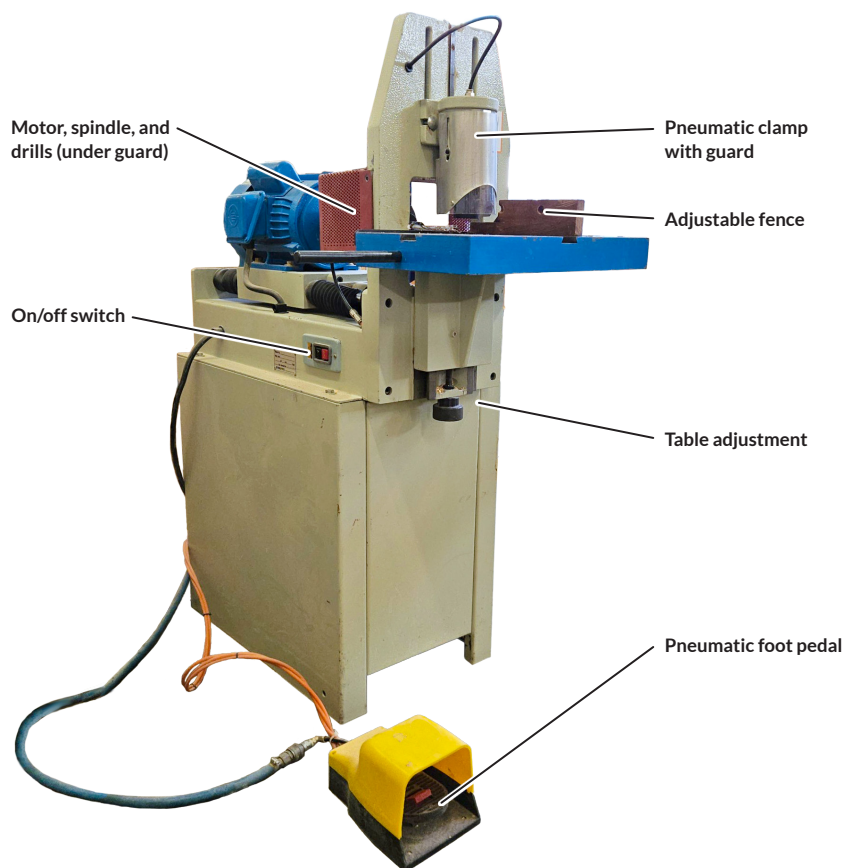
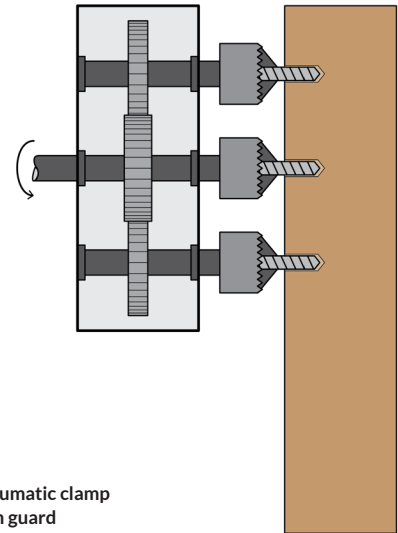

### Tips for use

- Always make sure the drill bit is tight in the chuck. Remember to remove the chuck key before starting.
- If your drill has a depth stop, set it to control how deep the hole goes; if not, adjust the fence position instead.
- Position the timber so the spot to be drilled is in line with the drill bit.
- Secure the workpiece before drilling. Some machines will have a clamp on the work table or a pneumatic ram.
- Pull the drill smoothly into the material. Don't force it. On deep holes, back out often to clean out the hole.

## Vertical drill press

Also called a pedestal or pillar drill, a drill press is a fixed machine used to drill accurate, straight holes in materials such as timber, plastics, and some metals. Because the material is supported on a table and the drill moves vertically, it is more accurate and safer than a handheld drill for many workshop tasks.

Drill presses come in a range of sizes, from heavy-duty standalone models to smaller bench-mounted machines.



### Tips for use

- Always make sure the drill bit is tight in the chuck. Remember to remove the chuck key and reset the chuck guard before starting.
- Position the timber so the spot to be drilled is directly under the drill bit.
- Place a piece of scrap wood under your workpiece to prevent breakout at the back.
- Secure the workpiece before drilling. Some machines will have a vice or clamp on the work table. Make sure the longest side extends to your left.
- If your drill press has a depth stop, set it to control how deep the hole goes; if not, adjust the table height instead.
- Lower the drill smoothly onto the material. Don't force it.
- When you release the feed handle it will automatically raise with a return spring.

# Shaping machinery

## Wood lathe

This machine is used to shape timber by spinning it while cutting tools are held against the surface. Instead of a moving blade (like a saw) cutting the timber, the timber rotates and the tool stays still. This process, called wood turning, is mainly used to make round or symmetrical objects.

**Spindle turning** - is when the timber is mounted between the headstock and tailstock and the grain runs along the length of the work.

It is commonly used to make long, thin objects such as table legs, tool handles, or candlesticks.

**Faceplate (or bowl) turning** - is when the timber is mounted to a faceplate or chuck, with the grain running across the work. It is used for bowls or plates.

The timber is often larger and more unbalanced, so turning usually starts at a slow speed and increases as the piece becomes round.

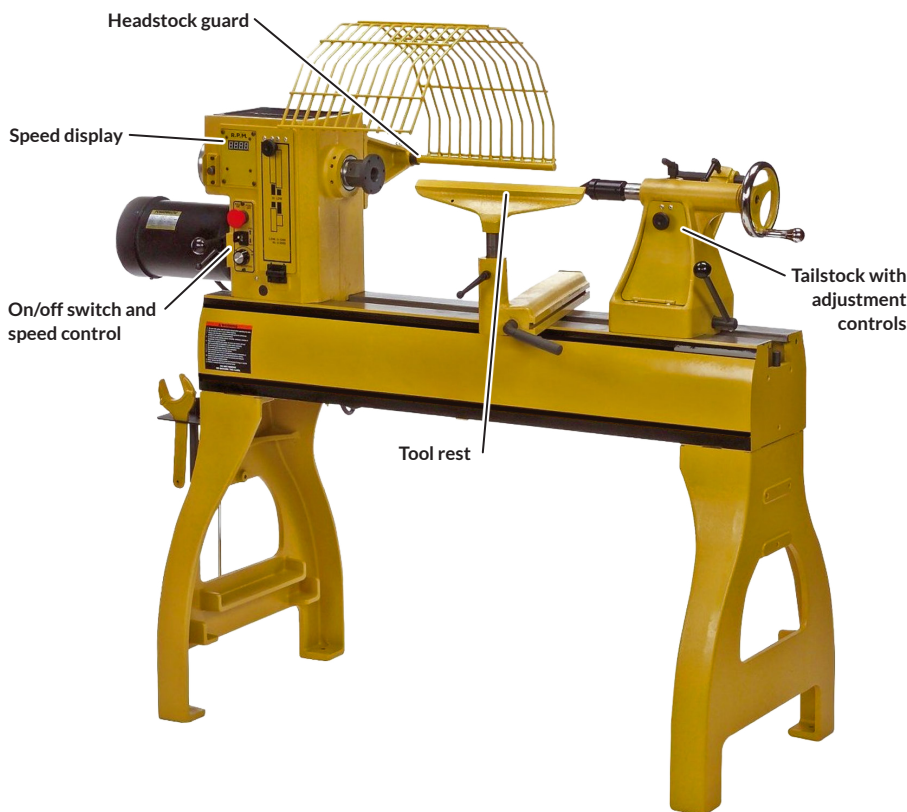
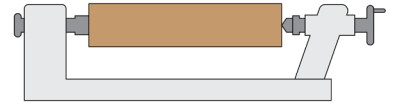

## Tips for use

- Make sure the workpiece is fixed securely to the faceplate or between centres.
- Rotate the workpiece slowly to make sure it clears the lathe bed and tool rest.
- Use only the specially designed gouges. They are fitted with extra-long handles designed to counteract the pull of the revolving timber.
- Check that the tools are sharp and undamaged before using them.
- Select the correct speed for the kind of work you are doing.
- Wait for the lathe to stop spinning before you adjust the tool rest.
- Return the tools to the tool tray.

## Spindle speed

Different tasks need different speeds so make sure to check this before you start. A display shows how fast the wood is spinning in revolutions per minute (RPM).

In general, the bigger the diameter, the slower the speed.

300 – 700rpm = Low speed – roughing down square timber.

800 – 1500rpm = Medium speed – shaping.

1600 – 3000rpm = Higher speed – sanding and finishing.

## Roughing gouge

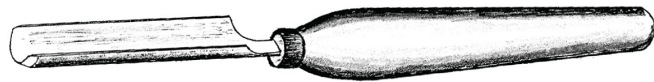

A large, strong gouge with a deep flute used only for quickly turning square stock into a round cylinder (spindle work). Never use for faceplate turning.

## Spindle gouge



Smaller than a roughing gouge, used for creating fine details like beads and coves on spindle work.

## Bowl gouge



Designed with a deep U or V shaped flute for safely and efficiently shaping the inside and outside of bowls and curved forms.

## Parting tool

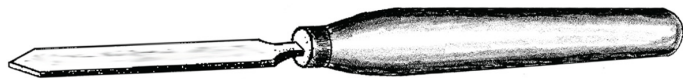

A thin, often rectangular or diamond-shaped tool used for cutting deep grooves and separating (parting off) the finished piece from waste wood.

## Skew chisel



A flat chisel with an angled cutting edge. Useful for planing smooth cylinders, cutting beads, and precise V cuts. Can be challenging to master due to its tendency to catch if positioned incorrectly.

## Scrapers

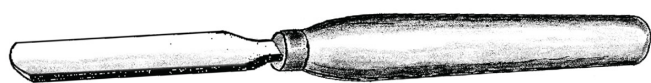

Flat tools used primarily for smoothing surfaces already shaped by gouges, particularly inside bowls or on flat areas. Use carefully to avoid catching.

**IMPORTANT**

The use of these machines may be restricted to the teacher only.

**Bench grinder**

This machine has two rotating abrasive wheels used mainly for shaping, sharpening, and cleaning metal tools. It usually has two wheels: a coarse one for rough grinding and a fine one for finishing. Some grinders might have a wire brush on one side for cleaning off rust or scale.

In school workshops it is most commonly used to:

- sharpen chisels, plane irons, and lathe tools
- shape or re-profile metal tools
- remove burrs or rough edges from metal.

Related to the grinder is the buffing machine. This machine uses buffing wheels made of soft fibrous fabrics. This machine is used to polish rather than shape.

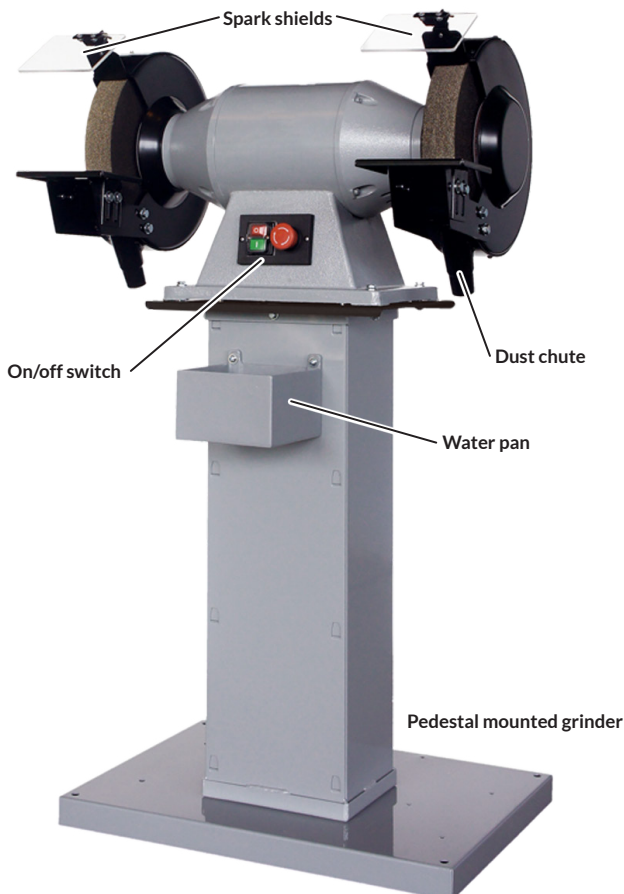
**Tips for use**

- Before starting work, make sure the grinder is firmly fixed to the bench, and there are no chips or cracks in the wheels.
- Make sure guards and guides are in place, and the shield is set in the correct position.
- Keep the adjustable work rest within 2 – 3mm of the wheel.
- Only grind steel. Other materials will clog up the wheel and cause it to explode.
- Stand on one side of the grinder when starting the machine and until it has reached its full operating speed.
- Do not use the side of the wheel as it could shatter.
- Do not overheat tools (dip in water regularly).

## Computerised machinery

Instead of being guided by hand, computer-controlled machines follow a programmed path to cut, drill, or shape materials by following a digital design, usually created with CAD (computer-aided design) software.

Untested projects will often fail at first and need to be modified. This process of changing and improving is called "iterative design". Remember, the machine is only as good as the thinking done before it starts.

Before a computerised machine is even switched on, you will need to have an understanding of:

- digital design methods
- what the machines can and cannot do
- the limitations of materials and how they will react in the machine.

---

### 3D printer

This is a computer-controlled machine that creates objects by building them up layer by layer from a digital design. Instead of cutting material away (like CNC), 3D printing adds material only where it's needed.

Most schools use printers which melt and fuse plastic filament to form solid objects. 3D printing is an effective way to rapidly model, prototype, or manufacture components.



#### Tips for use

- Make sure the printer is level and has been calibrated before you start.
- Only use approved materials.
- Work in a well ventilated area.
- Don't leave the printer running unattended.
- Never reach into the machine while it's working. The platter or nozzle can be very hot.
- Allow work to cool before removing it from the printer. Be careful when removing finished work as pieces might be stuck to the platter.

---

## Laser cutter

This is a computer-controlled machine that uses a laser beam to cut, engrave, or mark materials with a high level of precision.

Laser cutters are well suited to plastic, thin timber, veneer, cork, and some engineered boards. The depth they can cut is limited compared with traditional woodworking machines, so they are not used for cutting thick structural timber.

Laser cutting produces smoke, fine particles, and fumes, so extraction systems must be operating correctly before starting any job. Wood and plastics are combustible, and flare ups can occur, particularly with resinous timber or slow cutting speeds.



### Tips for use

- Make sure the material is flat against the bed and that the laser is correctly focused. Use test cuts to find the correct speed and power settings.
- Never leave a laser cutter unattended and know how to stop the machine or respond to fire quickly if required.
- Keep optics and the bed clean. Residue buildup on lenses and mirrors increases the risk of overheating and reduces cut precision.

## CNC router

In school workshops, computer numerically controlled (CNC) routers can be used with timber, engineered wood products, plastics, and sometimes aluminium. Industrial machines can also work with other materials like stone and steel.

Common uses in a school workshop include:

- cutting accurate and repeatable shapes out of sheet materials
- creating complex or curved shapes that are hard to do by hand
- engraving text, patterns, or logos.

CNC machines are ideal for making modular flat-pack style furniture and cabinetry as well as complex decorative pieces.

Make sure your CAD file is set up to get the most out of your sheet material. Nesting multiple components and setting grain direction are things you will need to discuss with your teacher.



### Tips for use

- Make sure the guards and safety devices are in place.
- Test the programme with a 'free air run', which means running the machine without any material on the bed.
- Turn off the machine before adjusting the cutter head or tool setup.
- Make sure the router bit size matches the requirements in the project brief.
- Make sure all cutters are sharp and clean, with no damage or resin buildup.
- Only use materials that are suitable for CNC routing.
- Make sure the workpiece is held flat and secure on the table.
- Check that no one is near the machine before you start using it.
- Never leave the CNC router running without supervision and know how to stop the machine if required.





